

SUBDIVISION ORDINANCE

ARTICLE I. IN GENERAL

Section 66-1. Title of chapter

This ordinance shall be known and may be cited as the Stanly County Subdivision Regulations, and may be referred to as the Subdivision Regulations or Ordinance.

Section 66-2. Purpose of chapter

The procedures and standards for the development and subdivision of real property for residential, industrial, institutional, or commercial purposes and the surveying and platting thereof, as adopted and prescribed in this Ordinance, are hereby found by the Board of Commissioners of Stanly County to be necessary and appropriate. In doing so, these regulations shall:

- 1) aid in promoting the orderly development of the County and safeguard conditions essential to public health, safety, and the general welfare;
- 2) provide space for safe and sanitary dwelling accommodations within Stanly County;
- 3) promote safe and sanitary environmental conditions, proper planning, adequate light, air and space, safe and sanitary design and arrangements, supply sanitary facilities, and existence of conditions which enhance life or property, and hinder damage by fire or other causes of destruction;
- 4) provide for suitable neighborhoods with adequate streets, utilities and appropriate building sites;
- 5) save unnecessary expenditures of public funds by reserving space for public lands and buildings including the dedication or reservation of recreation areas and school sites, or fees in lieu of, to serve residents of the immediate neighborhood within the subdivision and to provide sufficient streets with adequate width and with proper alignment and grade for the coordination of utilities, planned streets and highways transportation networks, and other public facilities, and to facilitate adequate and orderly communication and travel within and between communities;
- 6) provide proper land records for the convenience of the public and for better identification and permanent location of real property boundaries; and,
- 7) ensure legal access to all newly divided parcels.

Section 66-3. Authority and jurisdiction of chapter

This ordinance is adopted under the authority of Chapter 160D of the General Statutes of North Carolina. On and after the date of adoption, these regulations shall govern each and every subdivision of land within Stanly County and outside the jurisdiction of any incorporated municipality. However, this ordinance may also regulate territory within the subdivision regulation jurisdiction of any municipality

whose governing body by resolution agrees to such regulation provided, however, that any such governing body may, upon six months written notice, withdraw its approval of these County Regulations, and those regulations shall not have further effect within the municipality's jurisdiction.

Section 66-4. Compliance with chapter required

Pursuant to G.S.160D-803 unless otherwise noted, no real property within the jurisdiction of this ordinance shall be subdivided or a plat thereof recorded until; a plan has been reviewed and approved by the Stanly County Planning Board as provided in these regulations. Plans of group developments for housing, commercial, industrial, or other uses, or for any combination of uses shall be submitted in the same manner as other plats for review by the Planning Board.

Section 66-5. Definitions

"SUBDIVISION" DEFINED

A "subdivision", as specified in General Statute 160D-802, shall include all divisions of a tract or parcel of land into two or more lots, building sites, or other divisions when any one or more of those divisions are created for the purpose of sale, or building development (whether immediate or future), and shall include all division of land involving the dedication of a new street or change in existing streets; however, the following shall not be included within this definition nor be subject to the regulations authorized by this ordinance:

- A. The combination or recombination of portions of previously platted and recorded lots where the total number of lots is not increased and the resultant lots are equal to or exceed the standards prescribed for new lots by this Ordinance, and the Stanly County Zoning Ordinance;
- B. The division of land in parcels greater than ten (10) acres where no street right-of-way dedication is involved;
- C. The public acquisition by purchase of strips of land for the widening or opening of streets or for public transportation system corridors.
- D. The division of a tract in single ownership whose entire area is no greater than two (2) acres into not more than three (3) lots, where no street right-of-way dedication is involved and where the resultant lots are equal to or exceed the standards prescribed for new lots by this Ordinance.
- E. The conveyance of a lot or tract for the purpose of dividing land among tenants in common, all of whom inherited, by intestacy or by will, the land from a common ancestor;
- F. The division of land pursuant to an order of the General Court of Justice; and
- G. The conveyance of a parcel or parcels which create lots for residential purposes which are to be deeded only to an Immediate Family member of grantor and cannot be resold or deeded to a person who is not an Immediate Family member of grantee for at least three years from the

date the lot is established. Qualifying parcels created must comply with applicable requirements of the Stanly County Zoning Ordinance.

H. The conveyance of a parcel of land less than 10 acres to a child of the grantor not abutting a public right-of-way with a dedicated easement with a minimum width of thirty feet. This exception is limited to one conveyance per person (grantee) approved by the Planning Department with a recorded plat. Qualifying parcels created must comply with applicable requirements of the Stanly County Zoning Ordinance.

OTHER DEFINITIONS

A. Abut - having property, district lines, rights of way or easements in common; e.g., two lots abut if they have property lines in common.

B Access - a way of approaching or entering a property from a street.

C. Address. The official house, building, or structure number assigned by the County for a specific lot, building or portion thereof.

D. Block - a parcel of land which is bounded on all sides by a public street or roadway.

E. Buildable Lot - a parcel of land of sufficient size to meet minimum zoning requirements for use, coverage, and area; and to provide such setbacks and other open spaces as required by other local ordinances.

F. Building - any structure designed or built for the support, enclosure, shelter, or protection of persons, animals, or chattels of any kind.

G. Building Setback Line –

- Front - a line establishing minimum allowable distance between the nearest point of any part of the structure or building and the street or highway right-of-way line when measured perpendicularly from the right-of-way.

- Side or Rear - a line-establishing minimum allowable distance between the nearest point of any part of the structure or building and the side and rear property lines. Covered porches, etc. whether enclosed or not and attached decks and steps shall be considered as part of the main building and shall not project into the required yard.

H. Cluster Development - a modern day planning concept that both uses land economically and aesthetically by generally:

1. physically grouping land uses together, and

2. leaving natural areas on site for both active and passive recreation, retention of scenic vistas, and for the avoidance of unbuildable areas due to floodplain, steepness of slope, or environmental reasons.

Specific techniques of clustering may include shared driveways, shared common areas (for example, play areas), longer than average setbacks with road frontage retaining an undeveloped, natural "feel", screening with trees, shrubs and other physical layout strategies that maximize the area's potential for development while retaining its unique topographic characteristics.

I. Control Corner - one or more corners in a development which serve as points of reference for the lots in that development.

J. Corner Lot - a lot which abuts the rights-of-way of two (2) streets at their intersection.

K. County Commission - the Board of Commissioners of Stanly County, North Carolina.

L. Dedication - the giving of a parcel of land by the subdivider to a public body for a specific purpose or for the general public use and the acceptance of the land by the public body.

M. Double Frontage Lot - a continuous lot accessible from both of the streets upon which it fronts. Corner lots are not included unless they front on three streets.

N. Easement. A grant of one or more of the property rights, by the property owner, to, or for use by, the public, a corporation, or other entities.

O. Flag Lot - a lot with street frontage that is less than the minimum lot width required by individual district regulations, and composed of a narrow "flagpole" strip extending from the street and a much wider "flag" section lying immediately behind another lot or lots or portion(s) of same having the required street frontage for a conventional lot. In the case of a flag lot, the lot line at the end of the flagpole lying parallel to the street to which the flagpole connects shall be considered to be the front lot line for setback purposes.

P. Half road - means any public or private street right-of-way or easement which is less than the full required width specified in this chapter, and which is established so that the additional half-width right-of-way or easement may be provided at a later date to complete a full-width roadway.

Q. Lot - a portion of a subdivision or any other parcel of land intended as a unit for transfer of ownership. The word 'lot' includes 'plot', 'parcel', or 'tract'.

R. Lot Area - The total area circumscribed by boundaries of a lot except that when the legal instrument creating a lot shows the boundary of the lot extending into a public road or private right-of-way, then the lot boundary for purposes of computing the lot area shall be the road right-of-way line, or if the right-of-way line cannot be determined, a line running parallel to and 30 feet from the center of the traveled portion of the road.

S. Lot of Record. A lot, plot, parcel, or tract recorded in the Office of the Register of Deeds in conformance with the ordinance(s) in effect at the time of recordation.

T. Major Subdivision – Subdivisions not defined as a Minor Subdivision.

U. Minor Subdivision - Subdivision involving 4 or fewer lots or parcels subject to the regulations of this ordinance, fronting on an existing, approved public or private road(s), not

requiring any new public road(s) or not requiring extension of a public sewer or water line, and not requiring a waiver or variance from any requirement of this Ordinance. Further division of property may not occur until 12 months has passed since the original subdivision was filed with the Register of Deeds. All other creation of lots is considered a Major Subdivision. (06/08/2020)

V. Non Access Easement - a ten (10) foot parcel of land adjoining and running parallel from a right-of-way in which vehicular encroachment (except for emergency access) is prohibited.

W. Planning Board - Planning Board of Stanly County, North Carolina.

X. Planned Development - land that is under unified control and planned and developed as a whole in a single development operation or a definitely programmed series of development operations. A planned development includes principal and accessory structures and uses substantially related to the character and purposes of the planned development.

Y. Planned Multi-Family Development - a group of two or more dwelling units intended for multiple ownership and established on a single tract. These developments must meet the requirements of General Statute 47A and the Stanly County Subdivision Regulations.

Z. Plat - includes the terms map, plot, replat, or replot. A map or plan of a tract or parcel of land that is to be, or which has been subdivided.

AA. Private Easement - an undedicated private right-of-way or easement which affords access to abutting properties which meets the requirements of Section 66-75 of this Ordinance.

BB. Reservation - withholding a parcel of land from development for a stated period of time for the purpose of making the land available for public acquisition at a later time.

CC. Reserve Strip - a parcel of land extending from a street right-of-way to the end of a property line.

DD. Road, Street, or Highway - a dedicated public or private right-of-way for vehicular or pedestrian traffic which meets one of the following definitions:

1. Private Roads - a dedicated right-of-way and/or road which may not meet the minimum standards of the NC Department of Transportation for public streets or have not been adopted for NCDOT maintenance.

2. Urban Roads - streets outside the Stanly County Thoroughfare Plan boundaries and classified in the Stanly County Thoroughfare Plan which is incorporated into this document by reference. The Stanly County Thoroughfare Plan shall include those portions of any other Thoroughfare plan adopted by any one of the Municipalities and NCDOT Board of Transportation. These are further divided into the following categories:

- a. Local Access Streets - designed only to provide access to abutting property. Streets may be residential, commercial, or industrial.

- b. Minor Thoroughfares - designed to collect traffic from local access streets.

c. Major Thoroughfares - the primary traffic arteries of the urban area providing for traffic movements within, around and through the area.

3. Rural Roads - those streets within the Stanly County Thoroughfare Plan boundaries and classified within the Stanly County Thoroughfare Plan which is incorporated in this document by reference. These are further divided into the following categories:

a. Principal Arterial System - a connected network of continuous routes which serve inter-county (or state) or intra-county (state) traffic.

b. Minor Arterial System - a network which links cities, towns, or other major traffic generators.

c. Collector Road System – intra-county routes of two types:

1. Major Collector Roads - streets providing service to the arterial system and major traffic generators.

2. Minor Collector Roads - streets providing service from the local road system to major collectors and arteries.

d. Local Road System - streets, which provide direct access to parcels such as cul-de-sacs, streets which do not connect thoroughfares or arteries, and streets serving less than one hundred dwelling units.

4. Marginal Access Street - a local or collector street which parallels and is immediately adjacent to an arterial road, and which provides limited access to abutting property and protection from through traffic.

EE. Rocky River RPO - a region defined for transportation planning purposes that includes the Rural areas and the towns of Stanly, Anson and the NON-MPO section of Union County.

FF. Sewage - the wastewater and its contents from kitchen, bathroom, toilet, lavatory and laundry of any residence, business establishment, industrial plant, institution, or any public building.

1. Central Sewage Disposal System - A sewerage system serving two (2) or more dwelling units and approved by the Stanly County Health Department and the North Carolina Department of Environmental Quality which provides a collection network and disposal system and central sewage treatment facility for a single development, community, or region. The State of North Carolina considers central sewage disposal systems to be "Public Systems". For the purposes of these regulations the following distinctions are made:

a. "Public Sewage Disposal System" shall mean a single system of sewage collection, treatment, and disposal owned and operated by a sanitary district, a water and sewer authority or district, a county, or municipality or another public utility.

b. "Community Sewage Disposal System" shall mean a privately owned central sewage disposal system or a system owned by a community association.

2. On-Site Sewage Disposal System - a septic tank or similar installation on an individual lot which utilizes an aerobic bacteriological process or equally satisfactory process for the elimination of sewage and provides for the proper and safe disposal of the effluent, subject to the approval of health and sanitation officials having jurisdiction.

GG. Sidewalks shall comply with the Americans with Disabilities Act where required.

HH. Subdivider - any person, firm or corporation who subdivides or develops any land which is a subdivision as herein defined.

II.1 Substantially Commenced Work (Substantial Expenditure) - 25% or more of the total estimated cost of the project as permitted, including costs of engineering, design/planning, grading, infrastructure, material, construction, erection, alteration, excavation, demolition, or similar work, must be completed within 2 years in order to establish a vested right. An additional 25% or more (for a total of 50% or more) of the total estimated cost of the project as permitted, including costs of engineering, design/planning, grading, infrastructure, material, construction, erection, alteration, excavation, demolition, or similar work, must be completed within 4 years in order for the vested right to continue.

II.2 Technical Review Committee - a group consisting of County Planning Director, who shall serve as Chairman, County Manager, or designee, Utilities Director, or designee, Soil and Water Conservation Agent, Public School Superintendent, or designee, Emergency Management Director, or designee, Environmental Health Supervisor, or designee, Department of Environmental Health and Natural Resources Official, or designee, NCDOT Division Engineer, or designee and representatives of local utility companies.

JJ. Thoroughfare - any street designated on the adopted County Thoroughfare Plan. [See definition for "Road].

KK. Thoroughfare Plan - the map and attendant documents approved by Stanly County Commissioners. The adopted Thoroughfare Plans are incorporated in this document by reference.

LL. Growth Area - that part of the County characterized by medium to high-density growth. Typically these are areas that will become incorporated into a municipality at some time. The adopted Stanly County Land Use Plan will identify Growth Areas on a map.

MM. Water System (Public) - shall mean a county, municipal, sanitary district, water and sewer authority or district owned system for the provision to the public of piped potable water for human consumption.

NN. Water System (Community) - shall mean a privately owned system for the provision to the public of piped potable water which serves 15 or more service connections or which regularly serves 25 or more individuals. For the purposes of regulation of water quality, the state considers these systems to be Public Water Systems.

OO. Family Subdivision - one or more divisions of a tract of land to convey the resulting parcel(s), with the exception of parcel(s) retained by the grantor, to an Immediate Family member, as a gift or for consideration, but only if no more than one parcel from such tract is conveyed by the grantor to any one Immediate Family member.

PP. Immediate Family - Husbands, wives, mothers, fathers, brothers, sisters, children (biological, adopted or step), grandmothers, grandfathers, grandchildren (biological, adopted or step), aunts, uncles, nieces, and nephews (biological, adopted or step) and surviving spouses.

WORD INTERPRETATION

A. For the purpose of this ordinance, certain words shall be interpreted as follows:

1. The present tense includes the future tense and future tense includes the present tense.
2. The singular number includes the plural number and the plural number includes the singular number.
3. The words "should" and "may" are permissive.
4. The words "shall" and "will" are mandatory.

Section 66-6. Sale of land in unapproved subdivision

A. The sale of land in subdivisions which have not been approved by the Planning Board is prohibited. The County, through its County Attorney or other official designated by the Board of County Commissioners, may enjoin such illegal transfer or sale by action for injunction and order requiring the offending party to comply with the subdivision ordinance. Building permits required pursuant to G.S. 160D-1110 may be denied for lots that have been illegally subdivided. In addition to other remedies, a county may institute any appropriate action or proceedings to prevent the unlawful subdivision of land, to restrain, correct, or abate the violation, or to prevent any illegal act or conduct.

B. The provisions of this section shall not prohibit any owner or its agent from entering into contracts to sell or lease by reference to an approved preliminary plat for which a final plat has not yet been properly approved under the subdivision ordinance or recorded with the register of deeds, provided the contract does all of the following;

- 1) Incorporates as an attachment a copy of the preliminary plat referenced in the contract and obligates the owner to deliver to the buyer a copy of the recorded plat prior to closing and conveyance.
- 2) Plainly and conspicuously notifies the prospective buyer or lessee that a final subdivision plat has not been approved or recorded at the time of the contract, that no governmental body will incur any obligation to the buyer or lessee with the respect to the approval of the final subdivision plat, that changes between the preliminary and final plats are possible, and that the contract or lessee may be terminated without breach by the

buyer or lessee if the final recorded plat differs in any material respect from the preliminary plat.

3) Provides that if the approved and recorded final plat does not differ in any material respect from the plat referred to in the contract, the buyer or lessee may not be required by the seller or lessor to close any earlier than five days after the delivery of a copy of the final recorded plat.

4) Provides that if the approved and recorded final plat differs in any material respect from the preliminary plat referred to in the contract, the buyer or lessee may not be required by the seller or lessor to close any earlier than 15 days after the delivery of the final recorded plat, during which 15-day period the buyer or lessee may terminate the contract without breach or any further obligation and may receive a refund of all earnest money or prepaid purchase price.

C. The provisions of this section shall not prohibit any owner or its agent from entering into contracts to sell or lease land by reference to any approved preliminary plat for which a final plat has not been properly approved under the subdivisions ordinance or recorded with the register of deeds where the buyer or lessee is any person who has contracted to acquire or lease the land for the purpose of engaging in the business of construction of residential, commercial, or industrial buildings on the land, or for the purpose of resale lease of the land to persons engaged in that kind of business, provided that no conveyance of that land may occur and no contract to lease it may become effective until after the final plat has been properly approved under the subdivision ordinances and recorded with the register of deeds.

Section 66-7. Other laws, ordinances or regulations

Whenever the provisions of any local, state or federal law, ordinance or regulation impose higher standards than are required by the provisions of this ordinance, the provisions of such law, ordinance or regulations shall govern.

Section 66-8. Exceptions to chapter provisions

Where because of the size of the tract to be subdivided, its topography, the condition or nature of adjoining areas or the existence of other unusual physical conditions, strict compliance with the provisions of this ordinance would cause an unusual and unnecessary hardship on the subdivider, the Planning Board may vary the requirements set forth herein. In granting exceptions, the Planning Board may require such conditions as will secure, insofar as practicable, the objectives of the requirement varied. Any exception(s) authorized shall be entered in the minutes of the Planning Board meeting together with the circumstances that justified the exception(s) granted, and the conditions upon which the exception(s) was granted.

Section 66-9. Vesting Development Rights

A developer/owner may establish a vested right to complete their development project by submitting a site specific plan. A public hearing must be held by the Planning Board to review and approve the site

specific plan. Any variations from the original plan must have the consent of the Planning Board. Vested rights run with the land for a period of two years.

Sections 66-11--66-35. Reserved

ARTICLE II. PLATS

Section 66-36. Approval necessary

A. General - after the effective date of this Ordinance no subdivision plat of land within the County's subdivision regulation jurisdiction shall be filed or recorded until it shall have been submitted to and approved by the Stanly County Planning Director, as provided hereinafter in this Ordinance. No land shall be sold or transferred by reference to a plat that has not been approved and recorded in accordance with the provisions of this Ordinance. No plat shall be recorded by the Stanly County Register of Deeds until this approval is entered in writing on the face of the plat as herein provided. Where an approved, recorded plat is required for compliance with the ordinance, a description by metes and bounds in the instrument of transfer or other document used in the process of selling or transferring land premised on an unapproved, unrecorded plat shall not be exempt.

B. Exemptions - if the Planning Director shall determine that the subdivision is exempt from the provisions of this ordinance, based on the criteria set forth in Section 66-5, the plat shall be endorsed to that effect and may be recorded with the Register of Deeds.

C. Appeal of Denied Exemption - the subdivider may appeal the denial of a requested exemption to the Stanly County Planning Board. This appeal must be made within thirty (30) days following the notification of the Planning Director's decision and must be made to the Planning Board in writing. The Planning Board shall calendar all such appeals for hearing by giving written notice to the subdivider at least ten (10) days prior to the hearing. The Planning Board in all such appeals shall make findings of fact in support of its decision. The proposed subdivider shall be notified in writing of the Planning Board's decision within ten (10) days after the said decision is made.

Section 66-37. Sketch plan requirements

A. General - prior to the filing of a Preliminary Plat the subdivider shall submit a pre-application sketch plat to the Planning and Zoning Department in order that the staff may make the subdivider aware of the purpose and objectives of these regulations and to assist him/her in planning their development.

Section 66-38. Abbreviated procedure for minor subdivisions

(A) Applicability

(1) The Planning Director or the Planning Director's designee shall approve or disapprove minor subdivision plats in accordance with the provisions of this Section. The Planning Director may refer minor subdivisions of 4 or less lots to the Technical Review

Committee for review and recommendation. A minor subdivision, as defined in Section 66-5, is a Subdivision involving 4 or fewer lots or parcels subject to the regulations of this ordinance, fronting on an existing, approved public or private road(s), not requiring any new public road(s), not requiring an extension of a public sewer or water line, and not requiring a waiver or variance from any requirement of this Ordinance. All other creations of lots are considered a Major Subdivision.

(2) Not more than a total of 4 lots may be created out of one tract using the minor subdivision plat approval process. Further division of property may not occur until 12 months has passed since the original subdivision was filed with the Register of Deeds. (06/08/2020)

(3) i. Subdivision streets giving access to one or two lots and having no collector characteristics for other lots within or adjacent to the proposed subdivision, may be designated on the plat as a private drive with a minimum of twenty (20) foot easement width and a minimum twelve (12) foot travelway width developed for ingress and egress.

ii. Subdivision streets giving access to three to four lots, and having no collector characteristics for other lots within or adjacent to the proposed subdivision, may be designated on the plat as a private drive, with a minimum thirty (30) foot easement width, and a minimum twenty (20) foot travelway width developed for ingress and egress. Re-divisions of lots served by existing access roads, streets or easements shall require upgrade of the roads to the highest applicable standard of this section.

(B) Minor Subdivision Review and Approval

(1) The applicant for minor subdivision plat approval is encouraged to confer with the Planning Director prior to submitting a minor subdivision plat for a determination of whether the approval process authorized by this Section can be and should be utilized. The Planning Director may require the applicant to submit information necessary to determine whether or not the proposed subdivision is eligible for processing under the minor subdivision approval process.

(2) The applicant for minor subdivision plat approval shall submit to the Planning Director a plat drawn in waterproof ink on a sheet made of material and of a size that will be acceptable to the Stanly County Register of Deeds Office for recording purposes. When more than one sheet is required to include the entire subdivision, all sheets shall be made of the same size and shall show appropriate match marks on each sheet and appropriate references to other sheets of the subdivision. The scale of the plat shall be at one inch equals not more than one hundred feet unless prior approval by the Planning Director. The applicant shall also submit six prints of the plat as well as any required application form and required fee.

(3) The Planning Director may review submitted minor final plats for approval, provided the subdivision involves four or fewer total lots or parcels subject to the requirements of this

ordinance. Divisions which are within 1500 feet of prior subdivisions in the same ownership or ownership interest are not eligible for this provision. Divisions, which are developmentally related to another subdivision (i.e. by shared road, utilities, or other improvements) are not eligible for this provision. Procedures for decision, notice, and appeals shall be the same as presented in Section 66-36(C), except that appeals from this abbreviated procedure shall be heard by the Stanly County Planning Board in the manner of a newly submitted subdivision proposal. Subdivisions reviewed for approval under this abbreviated procedure shall meet all requirements of this ordinance.

(4) The minor subdivision plat shall contain the following information:

- (a) The name of the subdivision, if applicable, which name shall not duplicate the name of any existing subdivision as recorded in the Stanly County Registry;
- (b) The name of the subdivision owner or owners;
- (c) The township, county and state where the subdivision is located;
- (d) The name of the surveyor and his registration number and the date of survey;
- (e) The scale according to which the plat is drawn in feet per inch or scale ratio in words or figures and bar graph;
- (f) All of the additional information required by NCGS §47-30, NCGS § 39-32.3, and Appendix 2;
- (g) All of the applicable certificates required in Appendix 2; and
- (h) Total acreage including gross and net usable acreage.

(5) The Planning Director shall take expeditious action on an application for minor subdivision plat approval. A decision shall be rendered by the Planning Director within ten working days after receipt of the proposed minor subdivision plat. If no decision is rendered by the Planning Director within the required 10-working day period, the applicant may appeal to the Planning Board for review of the application under the major subdivision approval process. Either the Planning Director or the applicant may at any time refer the application to the major subdivision approval process.

(6) Subject to subsection (5), the Planning Director shall approve the proposed subdivision unless the subdivision is not a minor subdivision as defined in Section 66-5 or the application or the proposed subdivision fails to comply with any other applicable requirement of this Ordinance.

(7) If the subdivision is disapproved, the Planning Director shall promptly furnish the applicant with a written statement of the reasons for disapproval.

(8) Approval of any plat is contingent upon the plat being recorded within sixty days after the date the Certificate of Approval is signed by the Planning Director or his designee. Failure to record the approved plat within the specified 60-day period shall render the plat null and void.

(9) Minor subdivisions with three or more lots that are accessed by an easement shall be approved by the Stanly County Fire Marshal.

Section 66-39. Preliminary plat requirements and review process – Major Subdivision

(A) Applicability

(1) A major subdivision, as defined is a subdivision involving more than 4 lots, or requiring a new public road(s), or extension of any easement(s), public road(s) for access to interior property, or requiring extension of public sewer or water line, or requiring a waiver or variance from any requirement of this Ordinance.

(2) The procedures for the review of a major subdivision generally involve (i) sketch design plan review and approval by the Technical Review Committee(TRC), (ii) a preliminary plat review and approval by the Technical Review Committee, and Planning Board and (iii) a final plat review and approval by the Planning Director. In all cases, compliance with 66-39 (B) (1)-(2) and 66-39 (C) 1-13 shall apply.

(B) Preliminary Plat

The preliminary plat is the first graphic document, which indicates the proposed division of land into lots and/or streets. The following procedures and requirements must be followed to get preliminary plat approval:

(1) Conformance with Sketch Plan

The preliminary plat shall conform substantially to the approved sketch plan. If the submitted preliminary plat deviates in its overall design from the approved sketch, or if the applicant requests a waiver from any of the standards of this Ordinance, the Planning Director shall schedule the preliminary plat to be reviewed by the Technical Review Committee and Planning Board. Such review shall follow the same review and approval procedures set forth in Section 66-37 for sketch plans.

(2) Submission Requirements

The applicant for preliminary subdivision plat approval shall submit, at least 25 calendar days prior to the regularly scheduled Planning Board meeting at which the plat will be considered, 15 prints of the proposed subdivision. If there is a new public or private road, or extension of an existing road, 2 complete sets of road construction plans, meeting the most current NCDOT road construction application requirements, shall be submitted with the preliminary plat. When more than one sheet is required to include the entire subdivision, all sheets shall show appropriate match marks on each sheet shall be made of the same size and appropriate references to other sheets of the subdivision. The scale of the plat shall be at one-inch equal not more than one hundred feet, except subdivisions with all lots greater than 5 acres or more may be at one-inch equals not more than two hundred feet. The applicant shall also submit any required application forms and any required fee. Preliminary plats that are submitted after the Planning Board has approved a sketch, and is consistent with the approved sketch, and does not require a waiver or variance from any requirement of this Ordinance, can be approved by staff once all comments have been received and approved by all members of the TRC. If any member of the TRC, or staff, determines that the preliminary plat should be resubmitted to the TRC, and/or Planning Board, the conditions and reasons shall be in writing with reference to specific section(s) of the Ordinance and sent to the owner, developer, and surveyor.

If a sketch plan has not been submitted and approved or if the preliminary plat is not substantially consistent with the approved sketch, then the plat shall be submitted 25 calendar days prior to the regularly scheduled Planning Board Meeting. If the Planning Board grants the conditional approval of the preliminary plat, the conditions and reasons thereof shall be stated in writing. If the Planning Board disapproves of the preliminary plat, the reasons for disapproval shall be stated in writing and reference shall be made to the specific section(s) of this Ordinance with which the plat does not comply. If the Planning Board fails to render a decision on the preliminary plat within 60 calendar days from the date that the plat is initially reviewed by the Planning Board, the Planning Director shall call a meeting with the developer, TRC members and a Planning Board committee. The proposal for resolve shall be submitted back to the full Planning Board for approval.

(C) All Preliminary Plats shall contain the following information:

1. The Title Block - it shall show the words "PRELIMINARY PLAT" and shall include the subdivision name, township, date, scale, and the name(s), phone number(s), and address(es) of the owner(s) and the designer(s) of the plan and his/her title. The title block shall be located on the bottom right corner of the plat. If the plan is part of a previously recorded subdivision, the old name, date and recording reference of the prior plat shall be stated.
2. Proposed Subdivision Data - the names and locations of all proposed streets, the location of all easements, lots, parks, reserve strips or other open spaces,

reservations, other property lines and building setback lines with dimensions of streets, lots and other property lines. The approximate area in acreage or square footage of each lot.

3. Survey - the boundary line on the tract to be subdivided shall be determined by an accurate survey prepared and signed by a registered surveyor in accordance with G.S. 47-30, or a clear declaration shall be shown on the map of how the map was prepared.

4. Existing Data - the location on the property or within three hundred (300) feet of the property; of any existing streets, rights-of-way, railroad lines, platted property lines, water courses, wooded areas, bridges, water mains, sewers, culverts, drain pipes, political subdivision lines, public and private easements, existing structures, zoning classification of the tract and of the adjoining property. The names of adjoining subdivisions, and/or property owner(s) and parcel identification numbers will also be shown.

5. North Arrow and Total Acreage of Subdivision - shall be shown on the plat.

6. Existing and Proposed Contours - at intervals of not more than five (5) feet shall be shown of the entire area to be subdivided and shall extend into adjoining property for a distance of one hundred (100) feet at all points where street rights-of-way connect to adjoining property.

7. Screening and/or Buffering - if any type of fence, brick wall, or earthen berm is being proposed to screen the proposed development, its location shall be shown and a typical section detailed on the preliminary plat. All areas of common ownership or landscaping shall also be noted and shown.

8. Utility Plans - proposed utility layouts and pipe sizes showing connections to existing systems or plans for central water or package sewer system, or designation for individual water and sewerage, storm sewers, gas, telephone, electric, cable TV, etc. Utility plans may be provided on a separate map.

If the subdivider plans to connect the utility system to public water and/or sewer utility system, such layout shall be accompanied by a letter from the public agency stating that they will accept the system for ownership or maintenance and that sufficient capacity exists to serve the subdivision.

If the proposed subdivision or development exceeds 200 acres or 200 single-family lots; or 300 multi-family or single attached units, an overall conceptual plan for future sanitary sewer, storm sewer, and water service is required regardless of ownership or if being proposed in phases or sections.

If public water and sewer is not currently available to the proposed subdivision, but will be extended to that area, then the subdivider may indicate on the face of the preliminary and final plats that the lots may be further divided, as permitted by zoning, when water and sewer is available to the site.

9. Lakes - where the plan for the subdivision includes a lake or pond one acre or more in size, existing or to be constructed, in connection with the development, the preliminary plat shall show the location of dams, spillways, and other structures and the location and extent of inundation at full reservoir. The preliminary plat shall also be accompanied by a profile of the proposed dam structure including all appurtenances and evidence of proper review by the North Carolina Department of Environmental Health and Natural Resources.

10. Location Map - a key map and/or vicinity sketch at a scale of 1"=2,000 feet showing the relation of the property to adjoining properties, and to all streets or roads existing within 1,000 feet of any part of the property to be subdivided. The Location Map shall be located at the upper left hand corner of the plat.

11. Road and Sidewalk Typicals - Typical cross sections shall be shown for each road and sidewalk type proposed within the subdivision.

12. Location of Flood Plain/River-Stream Buffer - subdivider shall show location of one hundred (100) year flood elevation and location of buffer strip as required by the Watershed Ordinance.

13. Urban Growth Area - Proposed developments that fall within one of the Urban Growth Areas must meet specific requirements of the appropriate urban municipality for roads, storm drainage, sediment and erosion control, etc. as applicable.

(D) Planning Board Review and Approval

The Planning Board shall review the Preliminary plan and the findings and recommendations of the TRC and Planning Staff, and any other reports or recommendations pertaining to the plan and shall approve, approve with conditions, or disapprove the preliminary plan.

(1) If the Planning Board authorizes the conditional approval of the preliminary plat, the conditions and reasons thereof shall be stated in writing.

(2) If the Planning Board disapproves the preliminary plat, the reasons for disapproval shall be stated in writing and reference shall be made to the specific section(s) of the Ordinance with which the plat does not comply. If the Planning Board fails to render a decision on the preliminary plat within 60 days from the date that the plat is initially reviewed by the

Planning Board, the Planning Director shall forward the application to the Board of Commissioners for review and approval, approval with conditions, or disapproval.

(3) If approval is granted, written confirmation shall be made on two copies of the preliminary plat. One copy of the approved preliminary plat shall be returned to the applicant. Approval of the preliminary plat is authorization for the applicant to proceed with the construction of the necessary improvements. Preliminary approval shall be valid for a period of 12 months from the date of approval of the plat by the TRC unless a longer time period is established under the vested rights provisions (Section 907 of the Zoning Ordinance). Preliminary plats whose approval has elapsed shall be resubmitted in accordance with Section 66-39 (B).

(E) Technical Review Committee Review and Approval

Upon receipt of the requisite copies of the proposed preliminary plat, the Planning Director or his designee shall schedule a meeting of the Technical Review Committee (TRC) to review the plat. The TRC shall review the preliminary plat and any other reports or recommendations pertaining to the plat and shall recommend, recommend with conditions, or disapprove the preliminary plat. The TRC shall be made up of the following members:

- Planning Director, Chairman
- County Manager, or designee
- Utilities Director, or designee
- Soil and Water Conservation Agent
- Public School Superintendent, or designee
- Emergency Management Director, or designee
- Environmental Health Supervisor, or designee
- Department of Environmental Health and Natural Resources Official, or designee
- NCDOT Division Engineer, or designee

(F) After preliminary approval has been granted, evidence from the proper agencies must be provided to show that road plans (including driveway permits), sediment/ erosion control plans, stormwater plans and water/sewer plans have been approved before any construction may begin.

Section 66-40. Final plat requirements

(A) Conformance with Preliminary Plat

The final plat shall conform substantially to the approved preliminary plat. If the submitted final plat deviates in its overall design from the approved preliminary plat, or if the applicant requests a waiver from any of the standards of this Ordinance, the Planning Director shall schedule the final plat to be reviewed by the Technical Review Committee and Planning

Board. Such review shall follow the same review and approval procedures set forth in Section 66-39 for preliminary plats.

(B) Submission Requirements

The applicant for final plat approval shall submit to the Planning Department a final plat made of material and of a size that will be acceptable to the Stanly County Register of Deeds Office for recording purpose consisting of five (5) reproducible originals of the final plat (all properly signed and executed as required for recording in the Office of the Register of Deeds of Stanly County) shall be submitted to the Planning Department. The plat shall be reviewed, and a recommendation presented to the Planning Director. When more than one sheet is required to include the entire subdivision, all sheets shall be made of the same size and shall show appropriate match marks on each sheet and appropriate references to other sheets of the subdivision. The scale of the plat shall be one-inch equals not more than one hundred feet, except when all lots are greater than 5 acres, the scale shall be one-inch equals not more than 200 feet. The applicant shall also submit any required application forms and any required fee. All final plats shall be submitted within 24 months of Preliminary Plat approval. No subdivision shall be granted final plat approval until required improvements either have been constructed or approved plans prepared and improvement execution guaranteed by a good and sufficient surety or performance bond (see Section 66-43) with corporate surety, a copy of which shall be filed with the Planning Director.

(C) Final Plat Contents:

The final plat shall contain the following information:

- (1) The name of the subdivision, which name shall not duplicate the name of any existing subdivision as recorded in the Stanly County Registry;
- (2) The name of the subdivision owner or owners;
- (3) The township, county and state where the subdivision is located;
- (4) The name of the surveyor and the surveyor s registration number and the date of survey;
- (5) The scale according to which the plat is drawn in feet per inch or scale ratio in words or figures and bar graph;
- (6) Restrictive Covenants - where restrictive covenants are proposed reference shall be made on the final plat as to deed book and page number of recorded covenants, or space shall be provided to insert the deed book and page number if the covenants have not been recorded.

(7) Road Maintenance - statement as to who will maintain the roads and drainage systems until such time when they may be turned over to the proper governmental agency for their maintenance. Deed Book and Page Number must be shown if a road maintenance agreement has been recorded for that purpose.

(8) Location of Floodplain/River-Stream Buffer Overlay – subdivider shall show location of one hundred (100) year flood elevation and location of buffer strip as required by the Floodplain/River-Stream Overlay.

(9) Final plat requirements - all final inspections by the public service providers must be complete and fees must be paid before the Planning and Zoning Director will sign the Certificate of Approval by the Planning and Zoning Director. Certificate number (6) as follows in Section (c) must be affixed to all final plats where public utility services are provided by any of the Municipalities or the County.

(10) All of the additional information required by NCGS § 47-30, NCGS § 39-32.3, and Appendix 2; and

(11) All of the applicable certificates required in Appendix 2.

(D) Planning Director Approval

The Planning Director shall approve the final plat unless the Planning Director finds that the plat fails to comply with one or more of the requirements of this Ordinance or that the final plat differs substantially from the plans and specifications approved for the preliminary plat. If the final plat is disapproved by the Planning Director, the applicant shall be furnished with a written statement of the reasons for the disapproval and reference shall be made to the specific section(s) of this Ordinance with which the plat does not comply.

When the final plat is approved by the Planning Director, a signed written certification to this effect shall be entered on the face of the plat in accordance with the requirements of Appendix 2.

The Planning Director shall take expeditious action on a final plat. If the Planning Director fails to act within 30 days after the final plat is submitted, the applicant may request that the final plat be reviewed for final plat approval according to the same review and approval procedures set forth in Section 66-39 for preliminary plats. The Planning Director may at any time, however, refer an application for final plat approval to the TRC and the Planning Board without regard to the 30 day time limit.

(E) Required Improvements

No final plat shall be approved until all required improvements have been installed and approved or appropriate surety has been provided as set forth in Section 66-43.

(F) Appeals From the Decision of the Planning Director on Final Plats

If a final plat is disapproved by the Planning Director, the applicant may appeal the decision by requesting that the final plat be scheduled for review according to the same review and approval procedures set forth in Section 66-39 for preliminary plats.

66-41 Recordation of Final Plats

(A) Plat Approval Contingent Upon Recordation

Approval of a final plat is contingent upon the plat being recorded in the Office of the Register of Deeds within 60 days after the approval date of the final plat. Failure to record the approved plat within the specified 60-day period shall render the plat approval null and void.

(B) Dedication and Acceptance

(1) Rights-of-Way and Easements

The approval and recordation of a final plat does constitute an offer to dedicate but does not constitute dedication to and acceptance for maintenance responsibility by the County or the public of any public road, alley, or utility or drainage easement shown on such plat. Improvements within such rights-of-way or easements, such as utility lines, road paving, drainage facilities, or sidewalks may, however, be accepted for maintenance by the North Carolina Department of Transportation or by the private utility provider upon compliance with applicable NCDOT and private utility provider guidelines and standards.

(2) Open Space and or Common Areas

Land designed as public open space and or common areas on a final plat shall be considered to be offered for dedication until such offer is officially accepted by the County. The offer may be accepted by the County through:

(1) Express action by the Board of Commissioners;

(2) Express action by an administrative officer designated by the Board of Commissioners; or

(3) Conveyance of fee simple marketable title (unencumbered financially and environmentally) of the property to the County at the time of final plat recordation.

Until such dedication has been accepted, land so offered may be used for open space and or common area purposes by the owner or by the owners' association. Land so offered for dedication shall not be used for any purpose inconsistent with the proposed public use.

(C) Permits and Certificates of Occupancy

Unless otherwise provided in this Ordinance, upon recordation of the final plat, the applicant shall be eligible to apply for building and any other permits required by this Ordinance, if the roads are determined by the Planning Director or his designee to be in a passable condition. No certificates of occupancy shall be issued until all improvements are complete and approved by NCDOT.

66-42 Owners' Associations

(A) Establishment of Owners' Association

(1) Creation

An Owners' Association shall be established to fulfill the requirement of the North Carolina Condominium Act or to accept conveyance and maintenance of all open space, common areas and facilities within a development containing common areas.

(2) Conveyance

Where developments have common areas for facilities serving more than one dwelling unit, these areas shall be conveyed to the Owners' Association in which all owners of lots in the development shall be members. All areas other than public road rights-of-way, other areas dedicated to the County, and lots shall be shown and designated as common areas. The fee-simple title of the common area shall be conveyed by the subdivider or developer to the Owners' Association.

(3) Subdivision or Conveyance of Common Area

Common areas shall not be subsequently subdivided or conveyed by the Owners' Association unless a revised preliminary plat and a revised final plat showing such subdivision or conveyance have been submitted and approved.

(4) Owners' Association Not Required

Developments involving only two units attached by a party wall shall not be required to have common areas or an Owners' Association. Developments with only two units attached and not having an Owners' Association shall have an agreement between owners concerning maintenance of party walls.

(B) Submission of Owners' Association Declaration

Prior or concurrently with the submission of the final plat for review and approval, the applicant shall submit a copy of the proposed Bylaws of the Owners' Association containing covenants and restraints governing the Association, plats, and common areas. The submitted documents shall be reviewed by the county attorney and a recommendation made to the Board of Commissioners as to their sufficiency. The restrictions shall include provisions for the following:

(1) Existence Before Any Conveyance

The Owners' Association declaration shall be organized and in legal existence prior to the conveyance, lease-option, or other long-term transfer of control of any unit or lot in the development. The developer shall not convey any control of any common areas until they have built or bonded all improvements thereon. The developer shall also have conveyed at least 40% of the lots to the final homeowner before conveying any common area control.

(2) Membership

Membership in the Owners' Association shall be mandatory for each original purchaser and each successive purchaser of a lot or unit. Provisions shall be made for the assimilation of owners in subsequent sections of the development.

(3) Owners' Association Declaration

(a) Responsibilities of Owners' Association. The Owners' Association declaration shall state that the association is responsible for:

- (1) the payment of premiums for liability insurance and local taxes;
- (2) maintenance of recreational and/or other facilities located on the common areas; and
- (3) payment of assessments for public and private improvements made to or for the benefit of the common areas.

(b) Default of Owners' Association. Upon default by the Owners' Association in the payment to the County of any assessments for public improvements or ad valorem taxes levied against the common areas, which default shall continue for a period of six months, each owner of a lot in the development shall become personally obligated to pay to the County a portion of the taxes or assessments in an amount determined by dividing the total taxes and/or assessments due to the County by the total number of lots in the development. If the sum is not paid by the owner within thirty days following receipt of notice of the amount due, the sum shall become a continuing lien on the property of the owner, his heirs, devisees, personal representatives and assigns. The County may either bring an action at law against the owner personally obligated to pay the same, or may elect to foreclose the lien against the property of the owner.

(c) Powers of the Association. The Owners' Association is empowered to levy assessments against the owners of lots or units within the development. Such assessments shall be for the payment of expenditures made by the Owners' Association for the items set forth in this Section, and any assessments not paid by the owner against whom such assessments are made shall constitute a lien on the lot of the owner.

(d) Easements. Easements over the common areas for access, ingress, and egress from and to public roads and walkways and easements for enjoyment of the common areas, and for parking, shall be granted to each lot owner.

(e) Maintenance and Restoration. Provisions for common area maintenance of and restoration in the event of destruction or damage shall be established.

(4) Nonresidential Condominiums

If the condominium is a nonresidential condominium, the declaration shall contain the following provision:

Parking spaces shall be allocated among the individual lots or units in such a manner that each unit is entitled to a sufficient number of parking spaces to comply with this Ordinance for the use intended to be located therein. The Owners' Association shall maintain a register listing the total number of parking spaces in the development and the number of parking spaces allocated to each lot or unit. A copy of this register shall be available to the Zoning Administrator at his request. The Owners' Association shall not reduce the number of parking spaces allocated to an individual lot or unit without the express written consent of the owner thereof, and in no case shall the number of parking spaces allocated to an individual unit be reduced to a number below that required by this Ordinance.

66-43 Sureties or Improvement Guarantees

(A) Agreement and Security

(1) Financial Guarantee in Lieu of Immediate Installation for Approval

In lieu of requiring the completion, installation, and dedication of all improvements prior to final plat approval, the County may enter into an agreement with the developer whereby the developer shall complete all required improvements. Once said agreement is signed by the developer and the security required herein is provided, the final plat may be approved if all other requirements of this Ordinance are met. To secure this agreement, the developer shall provide any or a combination of the following guarantees to cover the costs of the uncompleted improvements. A fee as specified on the county fee schedule shall accompany this agreement application:

(a) Surety Performance Bond(s)

(1) The developer shall obtain a surety bond from a surety bonding company authorized to issue said bonds in North Carolina.

(2) The bond shall be payable to Stanly County and shall be in an amount equal to 125 percent of the entire estimated cost, as approved by the County, of installing all uncompleted improvements. Developers must submit a request for bonding including a detailed construction cost estimate upon submission of the final plat.

(3) The bond amount and term shall be as approved by the Planning Director upon recommendation of the NCDOT and other consultants as deemed necessary.

(4) The County Attorney shall review the submitted bond and make a recommendation regarding its sufficiency to the Planning Director.

(b) Cash or Equivalent Security

(1) The developer shall deposit cash, an irrevocable letter of credit or other instrument readily convertible into cash at face value, either with the County or in escrow with a financial institution. The amount of deposit shall be equal to 125 percent of the entire estimated cost, as approved by the County, of installing all uncompleted improvements.

(2) If cash or other instrument is deposited in escrow with a financial institution as provided above, then the developer shall file with the County an agreement between the financial institution and himself guaranteeing the following:

i) that said escrow account shall be held in trust until released by the County and may not be used or pledged by the developer in any other matter during the term of the escrow; and

ii) that in case of a failure on the part of the developer to complete said improvements, the financial institution shall, upon notification by the County, immediately pay the funds deemed necessary by the County to complete the improvements, up to the full balance of the escrow amount, or deliver to the County any other instruments fully endorsed or otherwise made payable in full to the County.

(iii) All instruments shall be reviewed by the County Attorney and a recommendation regarding their sufficiency made to the Planning Director.

(2) Duration of Financial Guarantees

(a) The duration of a financial guarantee shall be of a reasonable period to allow for completion and acceptance of improvements. In no case shall the duration of the financial guarantee for improvements exceed one year.

(b) All developments whose improvements are not completed and accepted fourteen days prior to the expiration of the financial guarantee shall be considered to be in default. Said guarantee may be extended with the consent of the County, if such extension takes place prior to default.

(3) Default

(a) Upon default, the surety bonding company or the financial institution holding the escrow account shall, if requested by the County, pay all or any portion of the bond or escrow fund to the County up to the amount deemed necessary by the County to complete the improvements. Upon payment, the County shall expend such funds or portion thereof to complete all or any portion of the required improvements. The County shall return any funds not spent in completing the improvements. Default on a project does not release the developer from liability and responsibility for completion of the improvements.

(b) Release of Guarantee Security. The County may release a portion or all of any security posted as the improvements are completed and approved by the County. Proof satisfactory to the County that payment in full has been made to the applicable contractor and/or agency for the improvement(s).

Section 66-44. Phased developments

If a developer proposes that a subdivision (including planned developments) will be constructed in phases, the following procedure will apply:

- A. A master plan showing the entire proposed subdivision and phases of development, proposed density, proposed type and location of utilities, and proposed development timetable shall be submitted to the Planning Board.
- B. Each phase of development shall be preceded by submission and approval of a preliminary plat as outlined in Section 66-39. The master plan may be submitted prior to, or simultaneously, to the submission of the preliminary plat for the first phase of development.
- C. As each phase is completed, a final plat must be submitted and approved for that phase as outlined in Section 66-40.
- D. Approval of the master plan need not be renewed unless density increases are proposed.

Sections 66-45--66-65. Reserved

ARTICLE III. REQUIRED IMPROVEMENTS AND MINIMUM DESIGN STANDARDS

Section 66-66. Compliance of article with state and local law

All subdivisions and lots created under this ordinance must comply with the requirements of the Stanly County Zoning Ordinance and other applicable State and Local laws.

Section 66-67. Suitability of the land for use

A. Lands which are subject to flooding, excessive erosion, or slides because of soil types or groups, water courses and other drainageways, steep slopes, or other hazards shall not be platted for residential or other uses in such a way as to present a danger to life, property, or to the public health, safety or general welfare.

B. A subdivider proposing to use an existing lake must structurally upgrade the lake and dam, or if constructing a new lake and dam it must be in accordance with the North Carolina Dam Safety Act, or provide evidence that the lake does not fall under the provisions of that act.

C. All proposed subdivisions shall be planned so as to facilitate the most advantageous development of the entire neighboring area, including but not limited to road locations, utilities location, development of adjacent property, etc.

Section 66-68. Preservation of natural features and historical sites

Due consideration should be given to preserving natural features, such as trees, ponds, streams, rivers and lakes, as well as historical sites which are of value to the County as a whole. The proposed subdivision shall take advantage of and be adjusted to the contour of the land so as to produce lots and streets of reasonable gradient

Section 66-69. Name of subdivision and its roads

The name of a subdivision or its roads shall not duplicate nor closely approximate, either phonetically or by spelling, the name of an existing subdivision or roads within the County, within any municipality within the County, or in an adjacent County or municipality (if the development is in close proximity to another jurisdiction). All names must be approved by the County Communications Department. (06/08/2020)

Section 66-70. Flood damage prevention

Lots that are subject to flooding shall not be established in subdivisions for the purpose of creating building sites except as herein provided and in accordance with Flood Damage Prevention Ordinance of Stanly County.

1. If there is any water course of any type running through or within 150 feet of the property proposed for subdivision, the prospective subdivider shall provide evidence to the Planning Board, by making reference to maps prepared by the Federal Emergency Management Agency, that the lots within the subdivision will not be flooded.

2. The prospective subdivider shall make a determination of the crest elevation of a flood of 100 year probable frequency in accordance with generally accepted engineering practice. This determination must reflect the actual conditions imposed by the completed subdivision, and must give due consideration to the effects of urbanization and obstructions.

a. No proposed building lot shown that is wholly subject to flooding shall be approved.

b. No proposed building lot that is partially subject to flooding shall be approved, unless there is established on the lot plan a line representing an actual contour at an elevation two (2) foot above the 100 year flood. Such line shall be known and identified on the lot plan or the "building restriction flood line".

All buildings or structures designed or intended for use shall be located on such a lot so that the lowest usable and functional part of the structure shall not be below the elevation of the building restriction flood line. Usable and functional part of the structure is defined as being inclusive of living areas, basements, sunken dens, utility rooms, attached carports and mechanical appurtenances such as furnaces, air conditioners, water pumps, electrical conduits and wiring but shall not include water lines or sanitary sewer traps, piping and cleanouts provided openings serving the structure are above the building restriction flood line.

Where only a portion of a proposed building lot is subject to flooding, such lot may be approved only if there will be available for building, a usable lot area of not less than 1,500 square feet. The usable lot area shall be determined by deducting from the total lot area the area of the setback required by an applicable zoning district regulation and any remaining area of the lot lying below the building restriction flood line.

3. During the construction, preparation, arrangement, and installation of subdivision improvements, and facilities in subdivisions located at or along stream bed, the developer shall maintain the stream bed of each stream, creek, or backwash channel contiguous to the subdivision in an unobstructed state. The developer shall also remove from the channel and banks of the stream all debris, logs, timber, junk and other accumulations of a nature that would, in time of flood clog or dam the passage of waters in their downstream course. Installation of appropriately sized storm water drains, culverts or bridges shall not be construed as obstructions in the streams.

Section 66-71. River Stream Buffer

All subdivisions containing or located adjacent to all rivers or streams shown on USGS Quadrangle Maps as a solid blue line shall be subject to all of the regulations set forth in the Stanly County Zoning and/or Flood Damage Prevention Ordinance.

Section 66-72. Curb and Gutter and Sidewalks

Sidewalks are at the option of the developer and any horizontal portion of a curb and gutter is counted into the pavement width.

Section 66-73. Stormwater drainage

The subdivider shall provide for adequate drainage of all surface water. The purpose of the stormwater system is to control flooding and remove runoff from an area fast enough to avoid unacceptable amounts of ponding, damage, or inconvenience. Modifications of streams and other natural water courses is

prohibited unless approved by the North Carolina Department of Environmental Quality (NCDEQ) and the Army Corp of Engineers. Points of interception of runoff shall be frequent enough to avoid heavy concentrations in any one system and to eliminate or minimize any flooding. Points of discharge shall be within the site unless otherwise approved by the Planning Board and adjoining property owners. The subdivider shall provide retention/detention devices as may be applicable. Drainage calculations shall be based on a five year frequency in agricultural and residential areas if greater than two acre lots, with all others designed at a 100 year storm for on site drainage and a 25 year storm for through site drainage. Minimum pipe size shall be 15 inches diameter. Velocities in storm sewer, when flowing full at average peak flows, shall not be less than 2.0'/sec. nor greater than 20.0'/sec. Drawings and calculations shall be provided by and sealed by a NC Registered Engineer. Subdivisions that will occur within the Urban Growth Areas of the County shall meet the specifications and standards set forth in the respective city's subdivision ordinances where they pertain to stormwater drainage. The more stringent shall apply in every case.

Section 66-74. Water and sewer systems

Private wells and septic tanks must be approved by the Stanly County Health Department.

Water and wastewater systems which do not include individual wells and septic tanks are subject to the following:

- A. Connection to a public water and wastewater systems shall be in accordance with the policies and regulations of the Stanly County Utility Department or appropriate/responsible water/sewer agency.
- B. If a water or wastewater system is to be installed in a major subdivision in the County's jurisdiction, and the system is to be assumed and maintained by a municipality or the County immediately upon installation, a complete set of construction plans must be provided for the proposed system.

The plans shall be prepared by a professional engineer and shall meet the utility requirements of the municipality or county and the Division of Water Resources, North Carolina Department of Environmental Quality and the North Carolina utilities Commission. The plans shall be approved by the County's Utilities Department Director or the municipality's utility representative. The developer's engineer shall provide As-Built Plans and location maps for all valves and hydrant locations. In addition the developer's engineer must submit digital mapping information to the Stanly County GIS coordinator according to current technology standards.

- C. All community water and wastewater systems shall be designed by a professional engineer registered in the State of North Carolina constructed by a licensed Utility Contractor and be approved as follows:

1. Water and wastewater systems in all major subdivisions and planned developments shall be approved by the appropriate agency. Depending on the type of system, these agencies include the:

- a. NC Utilities Commission.
- b. NC Division of Water Resources of the Department of Environmental Quality(NCDEQ).
- c. Stanly County Utilities Department.
- d. Individual engineering department of municipality involved.

Proof of approval shall be provided to the Stanly County Planning Department before any work shall commence. Installation of the system shall be in accordance with the approved plan and shall be certified to the County by the registered engineer retained by the developer/owner. This shall be appropriately documented before construction.

2. Community water and wastewater systems shall be required to meet NCDEQ specifications and requirements of the NC State Utility Commission. (06/08/2020)

3. Water and wastewater systems to be connected to county or municipal systems shall be designed to County's or municipal specifications. The County or municipal utility department shall reserve the right to inspect the installation of the system and require as-built drawings.

Section 66-75. Public and private roads in major subdivisions.

A. Each road shown on a major subdivision plat shall be classified and designated as either public or private. The arrangement, character, extent, width, grade, and location of all roads shall be reviewed in relation to existing and proposed transportation patterns, topographical and other natural features, public convenience and safety, proposed uses of lands to be served by such roads and existing or potential uses in adjoining areas. New private roads and their related dedicated right of way shall not be allowed in a major subdivision.

B. Roads that are classified and designated as public shall be subject to the following conditions. Designation of a road as public shall be conclusively presumed to be an offer of dedication to the public and permit public use. THESE ROADS SHALL BE MAINTAINED BY THE DEVELOPER-OWNER, OR THE LOT PURCHASERS THROUGH A RECORDED MAINTENANCE AGREEMENT UNTIL THE RESPECTIVE GOVERNMENTAL AGENCY ASSUMES RESPONSIBILITY FOR THE MAINTENANCE.

1. All public roads must be designed and constructed to meet NCDOT minimum standards including paving and all current NC Fire Code requirements. Road plans must be properly approved and evidence of that approval provided to the Planning Department before any construction may begin.

2. The proposed road layout within a major subdivision shall be coordinated with the existing road system of the surrounding area, and existing roads shall be extended whenever possible. This includes connection of the road system to the road systems within adjoining subdivisions whenever possible, and the alignment of entrance roads with existing roads. Roads that are aligned with existing roads or connected to existing roads shall be given the same name as the existing road.

3. Where in the opinion of the Planning Staff it is necessary to provide for road access to adjoining parcels, a reserve connectivity strip for such purpose shall be extended to the boundary of such property(ies). When adjoining parcels develop the reserve strip shall be offered at market value to the adjoining property owner and the strip shall be developed by the adjoining owner as a continuation of the existing right-of-way and street. If a cartway or easement already exists to such a parcel, the reserve connectivity strip shall be provided at that point if practical.

4. All road, subdivision, and development names shall be subject to approval by the County Communications Department (911).

5. The developer shall bear the cost and the County shall install street name signs at all intersections as shown on the final plat. These signs will be erected only after all road and utility construction has been completed. The developer shall maintain such street name signs for one full year from installation.

6. The developer shall deposit a surety and guarantee as specified in section 66-43 for the continuing maintenance of dedicated public roads. 15% of the total cost of construction such roads, storm drainage, curb, gutter and sidewalks shall be deposited with the county until the road and other related improvements have been accepted for maintenance by a governing body or NCDOT. Reductions for accepted road improvements in the amount of the surety shall be allowed only once a year for each phase of the development.

7. The dedication of half roads at the perimeter of a new subdivision is prohibited.

Section 66-76. Access and thoroughfare planning

All major subdivisions or developments shall be subject to the following provisions relating to access to the public road system.

A. Direct access to public roads is governed by the classification of that road in the Rocky River RPO and/or County Thoroughfare Plans such that:

1. No lots may directly access a road classified as a major/minor thoroughfare or principal arterial. These lots must be served by an internal road system or marginal access street.
2. Access shall be limited where lots abut minor thoroughfares, minor arterials and major collector roads. The Planning Board may at their discretion prohibit direct access entirely, or may permit limited access based on analysis by Planning Staff and NCDOT Transportation Planners.

B. Major subdivisions or developments estimated to produce greater than 500 trips per day are required to provide a basic Traffic Impact Analysis (TIA). The number of trips per dwelling or other use is described in the “Instructions for the NCDOT TIA Checklist” and the “Policy on Street and Driveway Access to North Carolina Highways” and is based on the ITE Trip Generation Manual. The TIA must be produced by a qualified professional and must include, at a minimum, the following:

1. An estimation of traffic generated.
2. An estimation of trip distribution to and from the development.
3. An analysis of the existing road system serving the development (to the nearest major intersections) and the effect of the development on that system.
4. A listing of proposed improvements, both on and off-site, and their effect on the existing system.

C. A divided entrance and/or a second entrance will be required for a major subdivision or development when a Traffic Impact Analysis, the Fire Marshal, Planning Staff, or Planning Board determines it is necessary. Additionally, a subdivision containing 50 or more lots shall be required to have at least two entrances.

A divided entrance shall be four travel lanes from the intersection with the public road system to the first intersection within the development. A second entrance may be accomplished by a second intersection with the public road system or interconnection with an adjoining subdivision that accesses the public road system.

D. Where a tract of land to be subdivided borders on a proposed thoroughfare or a road requiring improvement as indicated in Rocky River RPO or the County/City Thoroughfare Plans, the owner/developer will be required to dedicate the necessary right-of-way for the proposed improvement. When dedication is required the developer

may reduce lot size to 95% of that required by the underlying zoning. The number of lots created after the reduction may not exceed the number that could have been created had no dedication been required.

E. Any major subdivision that will create in excess of 500 ADT (as projected by using ITE Trip Generation Manual) shall construct turn lanes at the entrance(s). These turn lanes shall be constructed to NCDOT specifications.

F. Reserve strips or non-access reservations that control access to roads, waterways, parks or the like, shall be permitted only if their purpose, location, dimensions, and manner of control are approved by the Planning Board.

G. No homes in a major subdivision shall be located on an access easement unless the easement forms a court or loop with at least two entrances onto a public road system. Any court or loop shall meet all easement requirements as specified in Section 66-83 except the court or loop may serve up to 12 residential lots.

Section 66-77. Monuments

Unless otherwise specified by this ordinance, the standards of practice for land surveying as adopted by the North Carolina State Board of Registration for Professional Engineers and Land Surveyors, under provisions of North Carolina General Statute Chapter 39, Article 5A shall apply.

Section 66-78. Construction procedures for major subdivisions

A. Construction or installation of improvements shall commence in a proposed subdivision after the preliminary plat has been approved, and all plans and specifications for roads, utilities and sedimentation and erosion control have been approved by the appropriate authorities.

B. During the construction phase the proposed road when adjoining an existing paved road, shall have a gravelway of at least one hundred (100) feet in length, eighteen (18) in width, with a gravel base of at least six (6) inches, to help eliminate excessive mud and other such materials from being carried onto the paved road.

C. Building or other permits shall be issued only for the erection of a structure on any lot of record prior to the adoption of this Ordinance or created in compliance with this ordinance and meeting all requirements of applicable State and local laws.

D. Major subdivisions served by public utility water shall have operational hydrants in place and approved by the Fire Marshal prior to the issuance of building permits.

Section 66-79. (Reserved)

Section 66-80. Reservation of School Sites

Schools sites must be reserved within the agreement of the Board of Education, in accordance with adopted subdivision plans of the Planning Board and/or Stanly County Board of Commissioners. Whenever a subdivision includes all or part of a site identified for new school construction, the Board of Education will be notified. That Board shall then notify the Planning Board whether it still wishes the site to be reserved. If the Board of Education does not wish for it to be reserved, no reservation will be required. If that board wishes for the site to be reserved the subdivision may not be approved without that reservation. The Board of Education must acquire the site within 18 months of the date of reservation. If the Board of Education has not acquired the site or begun the proceedings to condemn the site within the 18 months, the land is freed of the reservation.

Section 66-81. Reserved for future use

Sections 66-82. Clustering in a major subdivision

Every lot shall meet the minimum size as specified in the zoning ordinance except lots permitted to utilize the clustering provision. Lots in a major subdivision may be reduced using this provision but any lot area reduced shall be placed in a common area and shall in no way increase the number of lots normally allowed by using this section. Reference the Stanly County Zoning Ordinance for lot size requirements. Averaging lot size can be approved on a case by case basis by the Planning Board where no additional lots are created.

Section 66-83. Access Requirements

All lots must have public road access and frontage meeting the requirements set forth in the County Zoning Ordinance. The following exceptions may be approved:

- (1) Lots and units located in developments with Owners' Associations or in group developments in which permanent access is guaranteed by means of approved roads and/or drives.
- (2) Lots served by Access Easements meeting the following criteria:
 - (a) An Access Easement shall serve 4 or less residential lots;
 - (b) The minimum easement width shall be 30 feet and shall connect to a public road. This section does not apply to access easements as outlined in Section 66-38 (A)3i;
 - (c) There shall be, within the Access Easement, a minimum passable travel way of at least 20 feet in width with an unobstructed vertical clearance of 13.5 feet able to support the load of fire apparatus and surfaced to provide all-weather driving capabilities, and at a minimum be designed to the specifications in Figure 66-83 (1) Minimum All-Weather Path Standard.

If the easement is in excess of 150 feet and is a dead-end, an approved fire apparatus turnaround area shall be installed. Options for acceptable turn arounds are shown in figure 66-83(3) Turn Around Options, modifications of which may be approved by the Stanly County Fire Marshal. Cul-de-sacs with a 96' diameter

are also acceptable. This section does not apply to access easements as outlined in Section 66-38 (A)3i;

(d) The minimum separation between the proposed Access Easement and any other Access Easement on the same tract shall be 1500 feet;

(e) The location of the easement must be recorded on the plat;

(f) The Access Easement shall permit ingress, egress, and regress and necessary utilities required to serve the lot(s); and

(g) A notation shall be placed on the face of the plat which states that no additional lots, including re-subdivision of the lots served by the Access Easement, shall be permitted only when the Access Easement is upgraded by the property owner(s) to a private road or public road status and meets or exceeds the Stanly County private road standards or the NCDOT public road specifications, whichever is applicable.

(h) Flag Lots shall be consistent with the minimum road frontage in Section 402 of the Stanly County Zoning Ordinance unless written approval is provided by the Stanly County Fire Marshal.

Figure 66-83 (1) Minimum All-Weather Path Standard

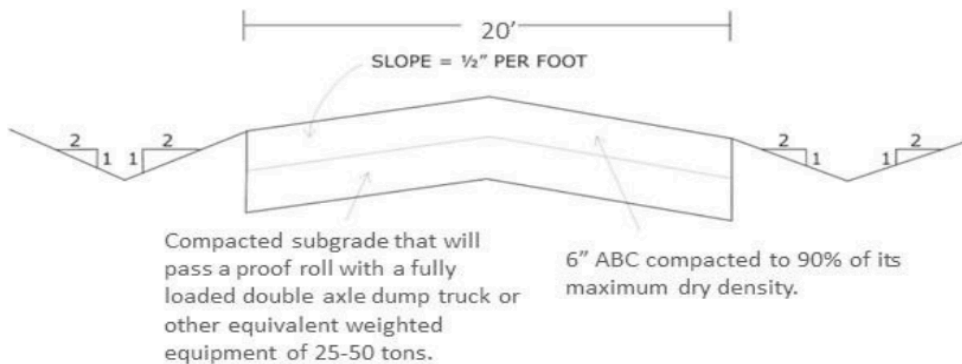
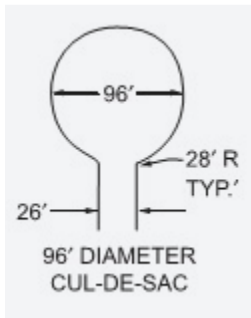
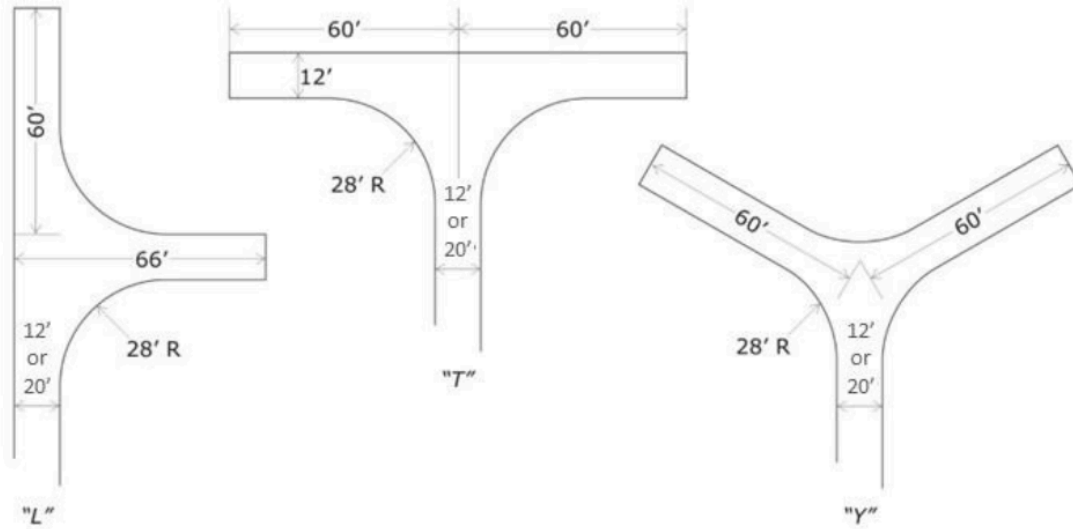

Figure 66-83 (3) Turn Around Options



Section 66-84 Open Space

Open space, where required, shall be limited to contain 50% flood plain or floodway or any other normally restricted or non-buildable land area.

Where the open space is less than 4 acres in size, and where the clustering provision is not used, the developer may opt out of this option and receive the points and credit for open space. In turn, the developer may retain this open space as un-developable land or combine it with one or more lots with the note that those lots can not be divided in the future to increase density of the approved subdivision.

Section 66-85 (Reserved)

Section 66-86 Street Construction

All major subdivisions shall have the following pavement widths unless a greater is required for NCDOT or appropriate municipal approval:

- Local Road System: 22-foot minimum back of curb to back or curb or 21 foot paved strip where curb and gutter is not required.
- Minor Collector Roads - 24-foot minimum back of curb to back or curb or 23 foot paved strip where curb and gutter is not required.
- Major Collector Road - 26-foot minimum back of curb to back or curb or 25 foot paved strip where curb and gutter is not required.
- Minor and Principal Arterial Systems – As required or suggested by NCDOT

Section 66-87 - 66-89 (Reserved)

66-90 Construction criteria point approval system

All major subdivisions shall obtain minimum 100 points for preliminary plat approval. This point system was developed to allow flexibility for the developer while maintaining a higher standard of subdivision construction and livability.

SUBDIVISION POINT SYSTEM

Improvement	Points	Criteria
Open Space	20-60	10%-50% e.g. 22% open space = 32 points, cluster open space can be counted for additional open space points.
Public Water	30	connected to a regulated public water system

Public Water in Growth Area	45	connected to a regulated public water system
Public Sewer	30	connected to a regulated public wastewater system
Public Sewer in Growth Area	45	connected to a regulated public wastewater system
Street Lighting	10	minimum of every 300 feet
Entrance Landscape and Sign	10	approved sign and landscaping
Dedicated Public Facility Site	10	EMS, library, fire station, etc.
Dedicated School Site	20	approved and accepted school site
Clustering with conservation design	35	clustering per these regulations with at least one recreation activity
Active Recreation	15	walking trails, ball fields, tennis courts, pools, playgrounds, etc.
Passive Recreation	15	vistas, ecological/environmental research preserves, farming, etc.
Tree Planting	10	4 on each lot, 2" caliper measured 6" from ground(May maintain at least 4 existing mature trees per lot)
Large lots (2-5 acre lot average)	40-100	total acreage outside of any right of way divided by the number of lots in the entire tract.
Sidewalks	10	per ADA requirements on one side
Sidewalks - both sides	20	per ADA requirements on both sides
Engineered Storm Drainage	20	designed and approved underground storm drainage
Curb and Guttering	25	standing or valley type
Homeowners Association(HOA)	10	recorded and enforced

66-91 Recreation areas in major subdivisions

1) Purpose and standards

A. Acceptable Types of active recreation. The purpose of active recreation areas is to provide adequate active recreational facilities for use by the residents of the immediate surrounding neighborhood within the development. Examples of facilities both serving active recreational needs and fulfilling the active recreation requirements of these regulations are:

- tennis courts
- racquetball courts
- swimming pools
- sauna and exercise rooms
- meeting or activity rooms within clubhouses

- basketball courts
- ballfields
- swings
- slides
- play apparatus

B. Each development using this should satisfy its active recreation requirement by installing the types of recreational facilities most likely suited to and used by the age bracket of persons likely to reside in the development. However, when five percent of the residents of any development are likely to be children under 12, then at least 15 percent of the active recreation requirement must be satisfied by construction of a “tot lot” - an area equipped with imaginative play apparatus oriented to younger children as well as seating accommodations for their parents.

C. Active recreation size. The total acreage of active recreation areas required for a residential development may be divided into areas of not less than 10,000 square feet.

D. Landscaping. Active recreation areas shall be attractively landscaped and be provided with sufficient natural or man-made screening or buffer areas to minimize any negative impacts upon adjacent residences.

E. Location and siting. Each active recreation area should be centrally located and easily accessible so that it can be conveniently and safely reached and used by those persons in the surrounding neighborhood it is designed to serve. Each active recreation area shall be constructed on flat, dry land capable of serving the purposes intended by these regulations.

Section 66-92 – 66-102. (Reserved)

Section 66-103. Ownership and maintenance

Ownership. Recreational facilities established on subdivision plats shall remain under the ownership and control of the developer (or his successor) or a homeowners’ association or similar organization.

Maintenance. The person or entity identified as having the right of ownership and control over a development’s recreational and open space area shall be responsible for the continuing upkeep and proper maintenance of the same.

Section 66-104. Homeowners’ association

In the event a homeowners' association or similar legal entity is to be responsible for the maintenance and control of recreational facilities established under these regulations, the association shall be established in conformance with the following:

When created. Provision for the establishment of the association or similar entity is made before any lot in the development is sold or any building occupied.

Authority. The association or similar legal entity has clear legal authority to maintain and exercise control over such common areas and facilities.

Contributions. The association or similar legal entity has the power to compel contributions from residents of the development to cover their proportionate shares of the costs associated with both maintenance and upkeep.

Section 66-105. Timing of recreational improvements

Because of the varying nature of subdivision developments, it is impractical to categorically set one time frame with applicability to all. Consequently, the timing of recreational improvements will be established for each development by reviewing staff in consultation with the developer. Generally, staff will require recreational improvements implemented when either 15 lots total or 50% of the total approved lots for the subdivision have been completed, whichever occurs first. When compliance with the preceding requirement does not occur, zoning permits for the remainder of the development may be stopped. Nothing, however, should be construed as barring a developer from immediate development of recreational facilities as an amenities/marketing strategy and such timing is encouraged.

Section 66-106. Lot reduction

Developers converting developable land area into the required recreational area may, at their option, reduce building lot size to 95 percent of the minimum lot size of the host zoning district.

Section 66-107. Flexibility in administration

Due to the widely varying characteristics of land itself, the nature of proposed facilities, or other factors, it is possible that the overall objectives of these regulations, on rare occasions, be achieved without adhering to the standards set forth with exact mathematical precision. Accordingly, minor deviations from these standards may be made when it can be determined that:

- i) the objectives of the standards can be met without strict adherence to them, or,
- ii) the peculiarities of a tract of land would make strict adherence to standards unreasonable

Section 66-108. Administrative procedures for deviation

A deviation from strict standards is to be presented within the regular subdivision review process, becoming both a part of the written record and also, receiving approval from the subdivision approving

body, the Stanly County Planning Board. Again, a deviation will be considered the exception rather than the rule and accordingly, be authorized only when the evidence is overwhelmingly in its favor.

ARTICLE V: LEGAL PROVISIONS

Section 66-109. Separability

If any portion, clause or sentence of this ordinance shall be determined to be invalid or unconstitutional, such declaration of invalidity shall not affect the remaining portions of this ordinance.

Section 66-110. Re-enactment and repeal of existing subdivision ordinance

The provision in part carries forward by re-enactment some of the provisions of the Subdivision Ordinance of the County of Stanly initially adopted and effective January, 1989 and subsequent revisions and updates. It is not the intention to repeal, but rather to re-enact and continue in force such existing provisions so that all rights and liabilities that have accrued there under are preserved and may be enforced.

All provisions of the Subdivision Ordinance, which are not re-enacted herein are hereby repealed. All suits at law for inequity and/or all prosecutions resulting from the violation of any subdivision ordinance heretofore in effect, which are now pending in any of the courts of this state or of the United States shall not be abated or abandoned by reason of the adoption of this ordinance, but shall be prosecuted to their finality the same as if this ordinance had not been adopted, and any and all violators of the existing ordinance prosecutions for which have not yet been instituted may be hereafter filed and prosecuted, and nothing in this ordinance shall be construed as to abandon, abate, or dismiss any litigation or prosecution, now pending and/or which may heretofore have been instituted or prosecuted.

Section 66-111. Effective date

This ordinance shall take effect and be in force from and after:

Date

County Commissioners Chairperson

Appendix 1

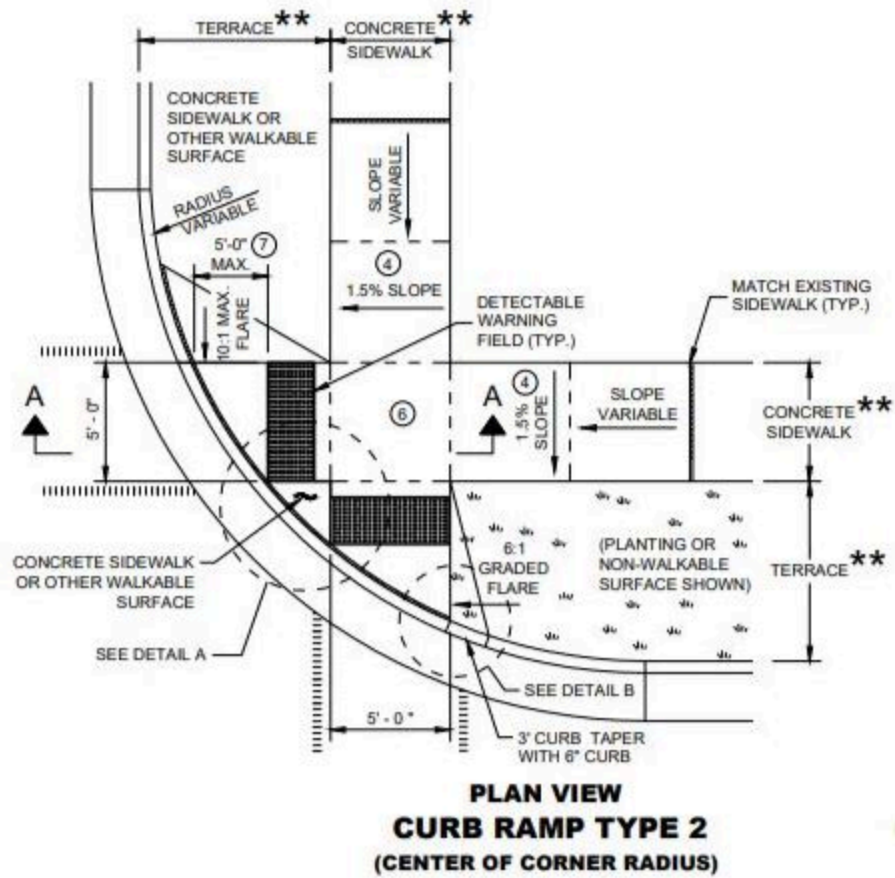

(ADA requirement), Handicap accessible at crossings and intersections. Must meet requirements shown above or as identified in the latest guidance in ADA Sidewalks and Curb ramps.

Appendix 2

Certifications - the following certificates shall be shown on the Final Plat as applicable:

1. CERTIFICATE OF OWNERSHIP AND DEDICATION

I (We) hereby certify that I am (we are) the owner(s) of the property shown and described hereon and that I (We) hereby adopt this plan of subdivision with my (our) free consent, established minimum building lines, and dedicate all roads, alleys, walks, parks, and other sites to the public use except as noted. Further, I (We) certify the land as shown hereon is within the platting jurisdiction of Stanly County.

Date

Owner/Developer

2. CERTIFICATE OF ACCURACY

[As required under General Statutes 47-30 as amended.]

Date

Registered Land Surveyor

3. CERTIFICATE OF APPROVAL BY THE PLANNING AND ZONING DIRECTOR

I, _____, Director of the Stanly County Planning and Zoning Department hereby approve the final plat of the subdivision entitled _____ on the _____ day of _____ month, of the _____ year.

Director

4. CERTIFICATE OF APPROVAL OF STREETS AND STREET DRAINAGE PLANS

Department of Transportation
Division of Highways
Proposed Subdivision Roads
Construction Standards Certification

APPROVED _____
Date District Engineer

5. CERTIFICATE OF ROAD MAINTENANCE

a. I (We) hereby certify that I (we) will maintain the roads to the standards set forth by the North Carolina Department of Transportation until the respective governmental agency takes over this responsibility. (This does not include removal of snow or ice)

Date Owner/Developer

b. Road maintenance shall hereby be the responsibility of the Homeowners Association and roads shall be maintained to the minimum standards of the North Carolina Department of Transportation until the respective governmental agency takes over this responsibility. The road maintenance agreement is recorded in Deed Book ____ Page ____ of the Stanly County Register of Deeds.

Date Owner/Developer

1. CERTIFICATE OF WATER AND SEWER CONNECTION FEE PAYMENT

(only if City public utility extensions are required).

I hereby certify that all water and sewer connection fees for the _____ Subdivision have been paid, or that the fees are not applicable.

Date Finance Director