

**STANLY COUNTY  
BOARD OF COMMISSIONERS  
REGULAR MEETING AGENDA  
OCTOBER 2, 2017  
7:00 P.M.**

---

**CALL TO ORDER & WELCOME – CHAIRMAN LAWHON  
INVOCATION & PLEDGE OF ALLEGIANCE – VICE CHAIRMAN BURLESON  
APPROVAL/ADJUSTMENTS TO THE AGENDA**

---

**SCHEDULED AGENDA ITEMS**

- 1. PROCLAMATION DECLARING OCTOBER AS DOMESTIC VIOLENCE AWARENESS MONTH**  
Presenter: Tracy Davis, Outreach Committee Chair
  
- 2. PRESENTATION CONCERNING REQUESTED CHANGES TO THE STANDARDS & POLICIES AT THE STANLY COUNTY AIRPORT**  
Presenter: Leighton Pressley, Pressley Aviation
  
- 3. PUBLIC HEARING TO REQUEST DESIGNATION OF A NO-WAKE ZONE IN THE AREA OF BEACH ROAD & PALMERVILLE ROAD**  
Presenter: Andy Lucas, County Manager
  
- 4. NEW HANGAR DEVELOPMENT PRESENTATION**  
Presenter: Ken Swaringen, Airport Director
  
- 5. BOARD & COMMITTEE APPOINTMENTS**  
Presenter: Andy Lucas, County Manager
  - A. Region F Aging Advisory Committee**
  - B. Norwood ABC Board**
  
- 6. “THANK YOU FOR YOUR SERVICE” DAY PROCLAMATION**  
Presenter: Andy Lucas, County Manager

## **7. CONSENT AGENDA**

**Presenter: Chairman Lawhon**

- A. Minutes – Regular meeting of September 5, 2017.**
  - B. Finance – Request acceptance of the Monthly Financial Report For Two Months Ended August 31, 2017.**
  - C. Sheriff's Office – Request approval of budget amendments # 2018-05 & 2018-06.**
- 
- 

**PUBLIC COMMENT**

**BOARD COMMENTS, ANNOUNCEMENTS & COMMITTEE REPORTS**

**CLOSED SESSION: To discuss a real estate transaction in accordance with G. S. 143-318.11(a)(5).**

**ADJOURN**

**The next regular meeting is scheduled for Monday, October 16, 2017 at 7:00 p.m.**

---



# Stanly County Board of Commissioners

Meeting Date: October 2, 2017

Presenter: Tracy Davis, Outreach Committee Chair

\_\_\_\_\_ | 1  
Consent Agenda | Regular Agenda

Presentation Equipment:  Lectern PC\*  Lectern VCR  Lectern DVD  Document Camera\*\*  Laptop\*\*\*

Please Provide a Brief Description of your Presentations format: \_\_\_\_\_

\* PC is equipped with Windows XP and Microsoft Office XP (including Word, Excel, and PowerPoint), Internet connectivity and Network connectivity for County Employees.

\*\* If you have need to use the Document Camera and zoom into a particular area, if possible please attach a copy of the document with the area indicated that you need to zoom into. A laser light is available to pinpoint your area of projection.

\*\*\* You can bring in a laptop that will allow video out to be connected at the lectern – set display to 60Mhz.

## ITEM TO BE CONSIDERED

### PROCLAMATION DECLARING OCTOBER AS DOMESTIC VIOLENCE AWARENESS MONTH

Subject

Please see the attached proclamation for Board consideration and approval.

Requested Action

Request approval of the proclamation.

Signature: \_\_\_\_\_

Dept. \_\_\_\_\_

Date: \_\_\_\_\_

Attachments: Yes \_\_\_\_\_ No    x   

#### Review Process

#### Certification of Action

	Approved		Initials
	Yes	No	
Finance Director	___	___	
Budget Amendment Necessary	___	___	
County Attorney	___	___	
County Manager	___	___	
Other:	___	___	

Certified to be a true copy of the action taken by the Stanly County Board of Commissioners on

\_\_\_\_\_  
Tyler Brummitt, Clerk to the Board      Date





## **DOMESTIC VIOLENCE AWARENESS MONTH PROCLAMATION**

**WHEREAS**, the family is the foundation of a safe and healthy community, it is a goal of the Board of County Commissioners for our neighborhoods to be safe;

**WHEREAS**, the problem of domestic violence affects all citizens of North Carolina crossing all racial, social, religious, ethnic, geographic, and economic groups;

**WHEREAS**, according to the NC Department of Justice, in 2016, there were 82 individuals (63 women and 19 men) who died as a result of domestic violence in North Carolina.

**WHEREAS**, domestic violence is an immense problem in Stanly County, where in 2016, 366 calls for service for domestic violence were answered by the Stanly County 911 Center;

**WHEREAS**, batterers of women are highly likely to abuse their children: 49% of batterers abuse their children, whereas 7% of non-abusive partners perpetrate violence against their children, according to a national study by Murray Strauss. The batterer's behavior often undermines the relationship between a mother and her children.

**WHEREAS**, Esther House served 129 women and 46 children in 2016, all who were victims of domestic violence and/or sexual assault;

**WHEREAS**, domestic violence is widespread, including one in three Americans who have witnessed an incident of domestic violence and with an annual cost to U.S. companies of billions of dollars in lost work time, increased health care costs, higher turnover, and lower productivity;

**WHEREAS**, in recognition of the impact that domestic violence has on the health and well-being of our community, we, the Board of County Commissioners, do hereby proclaim October 2017 as Domestic Violence Awareness Month.

**Further**, we affirm the commitment to reducing violence in our homes as well as on our streets. We urge all citizens to participate in the activities planned by battered women's programs and community organizations during this month. Citizens should also take this opportunity to educate themselves about the impact of domestic violence in North Carolina and to become familiar with resources and programs available. This month let us remember the victims of domestic violence, celebrate the survivors, and work together to eliminate violence against women and children from our community.

**Adopted this the 2<sup>nd</sup> day of October, 2017.**

\_\_\_\_\_  
**W. D. Lawhon, Jr., Chairman**  
**Board of County Commissioners**

**Attest:** \_\_\_\_\_  
**Tyler Brummitt, Clerk to the Board**





# Stanly County Board of Commissioners

Meeting Date: October 2, 2017  
 Presenter: Leighton Pressley, Pressley Aviation

Consent Agenda | Regular Agenda

2

Presentation Equipment:  Lectern PC\*  Lectern VCR  Lectern DVD  Document Camera\*\*  Laptop\*\*\*

Please Provide a Brief Description of your Presentations format: \_\_\_\_\_

\* PC is equipped with Windows XP and Microsoft Office XP (including Word, Excel, and PowerPoint), Internet connectivity and Network connectivity for County Employees.

\*\* If you have need to use the Document Camera and zoom into a particular area, if possible please attach a copy of the document with the area indicated that you need to zoom into. A laser light is available to pinpoint your area of projection.

\*\*\* You can bring in a laptop that will allow video out to be connected at the lectern – set display to 60Mhz.

## ITEM TO BE CONSIDERED

### PRESENTATION CONCERNING REQUESTED CHANGES TO THE STANDARDS & POLICIES AT THE STANLY COUNTY AIRPORT

Subject

Requested Action

No action required – for information only.

Signature: \_\_\_\_\_

Dept. \_\_\_\_\_

Date: \_\_\_\_\_

Attachments: Yes \_\_\_\_\_ No    x   

#### Review Process

#### Certification of Action

Approved		Initials
Yes	No	
Finance Director	___	___
Budget Amendment Necessary	___	___
County Attorney	___	___
County Manager	___	___
Other:	___	___

Certified to be a true copy of the action taken by the Stanly County Board of Commissioners on

\_\_\_\_\_

Tyler Brummitt, Clerk to the Board      Date \_\_\_\_\_



# Stanly County Board of Commissioners

Meeting Date: October 2, 2017

Presenter: Andy Lucas

Consent Agenda

3

Regular Agenda

Presentation Equipment:  Lectern PC\*  Lectern VCR  Lectern DVD  Document Camera\*\*  Laptop\*\*\*

Please Provide a Brief Description of your Presentations format: \_\_\_\_\_

\* PC is equipped with Windows XP and Microsoft Office XP (including Word, Excel, and PowerPoint), Internet connectivity and Network connectivity for County Employees.

\*\* If you have need to use the Document Camera and zoom into a particular area, if possible please attach a copy of the document with the area indicated that you need to zoom into. A laser light is available to pinpoint your area of projection.

\*\*\* You can bring in a laptop that will allow video out to be connected at the lectern – set display to 60Mhz.

## ITEM TO BE CONSIDERED

### PUBLIC HEARING TO REQUEST DESIGNATION OF A NO-WAKE ZONE IN THE AREA OF BEACH ROAD & PALMERVILLE ROAD

Subject

Please see the attached notice of public hearing which was placed in the newspaper on Thursday, September 14, 2017 related to this request.

Requested Action

- Hold the public hearing.
- Request Board approval of the resolution in support of an application to the NC Wildlife Resources Commission to approve this designation.

Signature: \_\_\_\_\_

Dept. \_\_\_\_\_

Date: \_\_\_\_\_

Attachments: Yes No    x   

#### Review Process

#### Certification of Action

Approved		Initials
Yes	No	
Finance Director	___	___
Budget Amendment Necessary	___	___
County Attorney	___	___
County Manager	___	___
Other:	___	___

Certified to be a true copy of the action taken by the Stanly County Board of Commissioners on

\_\_\_\_\_  
Tyler Brummitt, Clerk to the Board      Date









North Carolina  
County of Stanly

**RESOLUTION OF THE BOARD OF COUNTY COMMISSIONERS OF STANLY COUNTY**

**WHEREAS**, under the authority of North Carolina General Statutes Section 75A-15(a) any subdivision of the State of North Carolina may at any time, after public notice, make formal application to the North Carolina Wildlife Resources Commission for special rules and regulations with reference to the safe and reasonable operation of vessels on any water within its territorial limits; and

**WHEREAS**, Stanly County has given public notice of its intentions to make formal application to the North Carolina Wildlife Resources Commission for special rules and regulations with reference to the safe and reasonable operation of vessels on Palmerville Lake (part of Badin Lake – separated by railroad line) within its territorial limits of Stanly County and for the implementation of the Uniform Waterway Marker System in all the waters of the county; and

**BE IT RESOLVED**, that in accordance with N.C.G.S. 75A-15(a), the Board of Commissioners of Stanly County requests the North Carolina Wildlife Resources Commission to promulgate special rules and regulations with reference to safe and reasonable operation of vessels on the waters of Palmerville Lake (part of Badin Lake – separated by railroad line) located in said county, the pertinent substance of which proposed rules is as follows:

- A no wake zone designation for the cove and canal area directly adjacent to Beach Road and Palmerville Road on Palmerville Lake

**BE IT FURTHER RESOLVED**, the said Board of Commissioners requests the said Commission promulgate regulations fully implementing the Uniform Waterway Marker System in all of the waters of the said county.

**ADOPTED THIS THE 2<sup>nd</sup> DAY OF OCTOBER, 2017**

\_\_\_\_\_  
W.D. (Bill) Lawhon, Jr., Chairman  
Stanly County Board of Commissioners

**CERTIFICATION**

This is to certify the above is a true and exact copy of the resolution adopted by the Stanly County Board of Commissioners at the regular meeting held in the Commissioner’s Meeting Room located at 1000 N. First Street, Albemarle, NC 28001 on Monday, October 2, 2017. This same appears in Minute Book Number \_\_\_\_\_ at page \_\_\_\_\_.

(County Seal)

ATTEST:

\_\_\_\_\_  
Tyler Brummitt, Clerk to the Board



# Stanly County Board of Commissioners

Meeting Date: October 2, 2017  
 Presenter: Ken Swaringen, Airport Director

Consent Agenda | Regular Agenda

4

Presentation Equipment:  Lectern PC\*  Lectern VCR  Lectern DVD  Document Camera\*\*  Laptop\*\*\*

Please Provide a Brief Description of your Presentations format: \_\_\_\_\_

\* PC is equipped with Windows XP and Microsoft Office XP (including Word, Excel, and PowerPoint), Internet connectivity and Network connectivity for County Employees.

\*\* If you have need to use the Document Camera and zoom into a particular area, if possible please attach a copy of the document with the area indicated that you need to zoom into. A laser light is available to pinpoint your area of projection.

\*\*\* You can bring in a laptop that will allow video out to be connected at the lectern – set display to 60Mhz.

## ITEM TO BE CONSIDERED

### NEW HANGAR DEVELOPMENT PRESENTATION

Subject

Please see the attached information regarding Mr. Swaringen's presentation on behalf of the Airport Authority.

Requested Action

Request Board consideration and commitment to fund the Community Hangar Option 1 and approval to move forward with the design/completion of the Corporate Hangar Phase 1 site development.

Signature: \_\_\_\_\_

Dept. \_\_\_\_\_

Date: \_\_\_\_\_

Attachments: Yes \_\_\_\_\_ No \_\_\_\_\_ x \_\_\_\_\_

#### Review Process

#### Certification of Action

	Approved		Initials
	Yes	No	
Finance Director	___	___	
Budget Amendment Necessary	___	___	
County Attorney	___	___	
County Manager	___	___	
Other:	___	___	

Certified to be a true copy of the action taken by the Stanly County Board of Commissioners on

\_\_\_\_\_

Tyler Brummitt, Clerk to the Board      Date \_\_\_\_\_



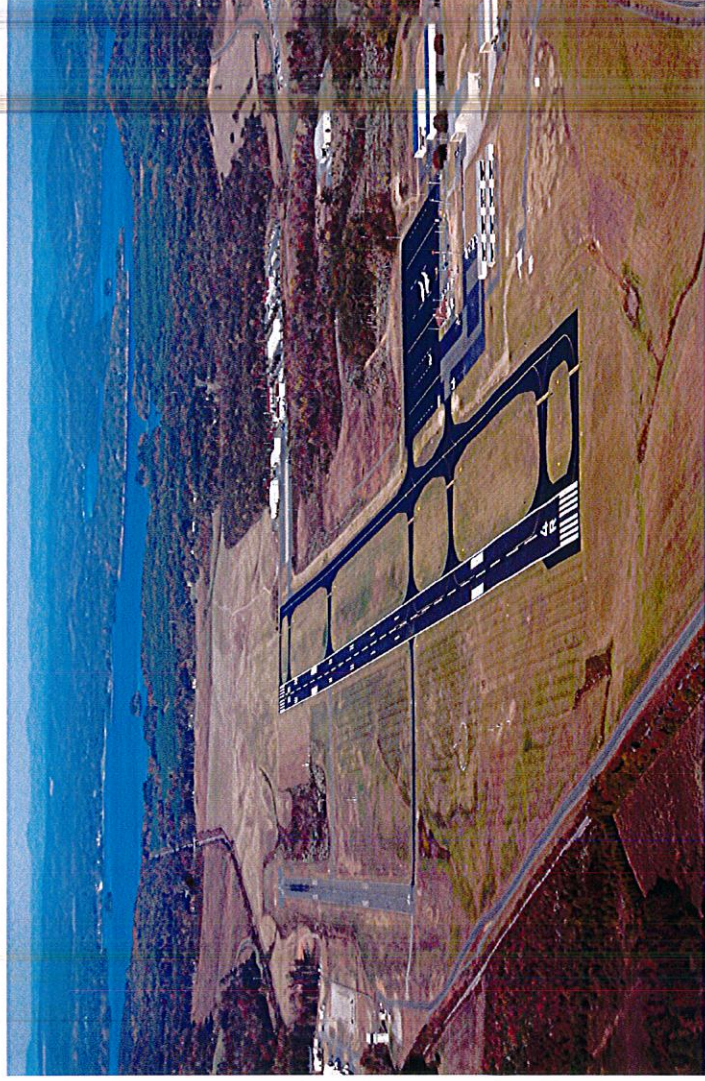

**New Hangar Development Presentation  
02 October 2017**



## **Objectives:**

- **Decrease shortfall of needed rental hangar space.**
- **Increase hangar rental revenue stream for airport.**
- **Flexibility to handle multiple and different size aircraft.**
- **Position airport to base larger corporate aircraft here.**
- **Positive addition for airport and EDC marketing efforts.**
- **Maintain competitive position with other similar airports.**
- **Intelligently use property that requires less site prep, allows more investment in actual hangar space.**



**Where we are today.**





## Hangar Complex A and B



**Completed in 2006**

**Site Development Cost - \$722,000**

**Hangar Cost - \$701,000**



# Stanly County AIRPORT

## Hangar A

4 aircraft spaces – all occupied

Accommodates:



Cessna 172 (Skyhawk)

Up To:

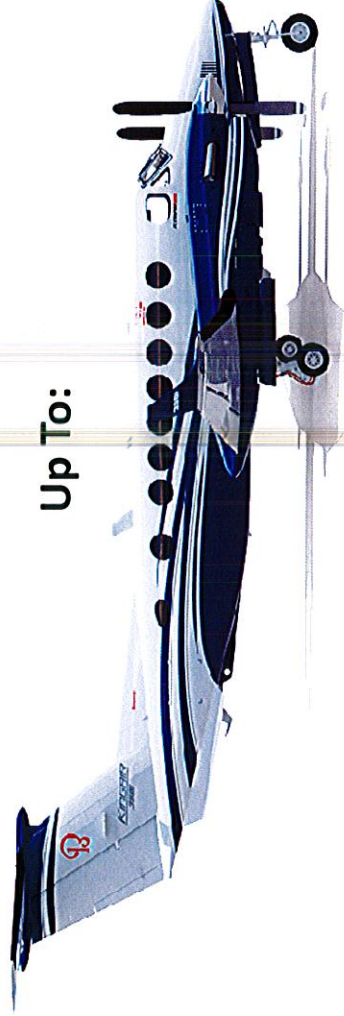

Beechcraft King Air B300

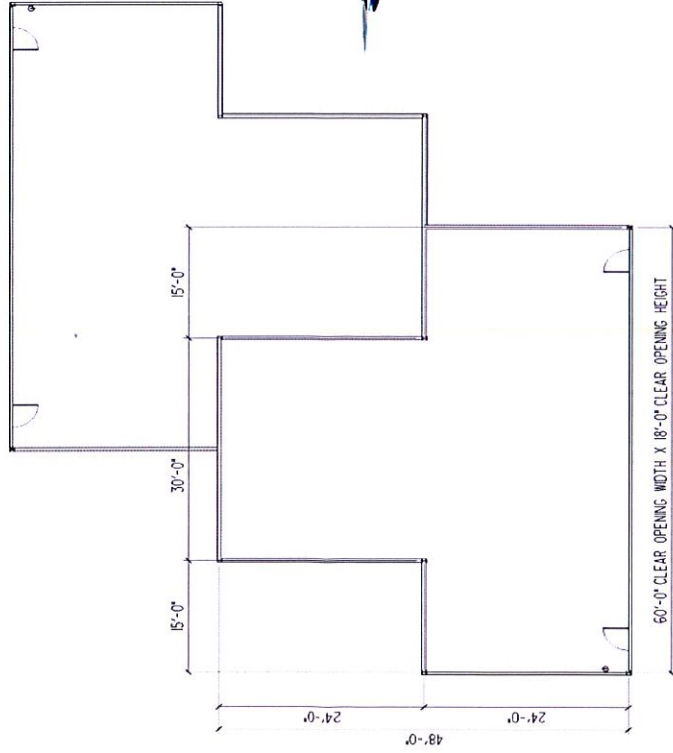



**Hangar B**  
**10 aircraft spaces – all occupied**

**Accommodates:**



**Cessna 172 (Skyhawk)**

**Up To:**



**Beechcraft 58TC (Baron)**

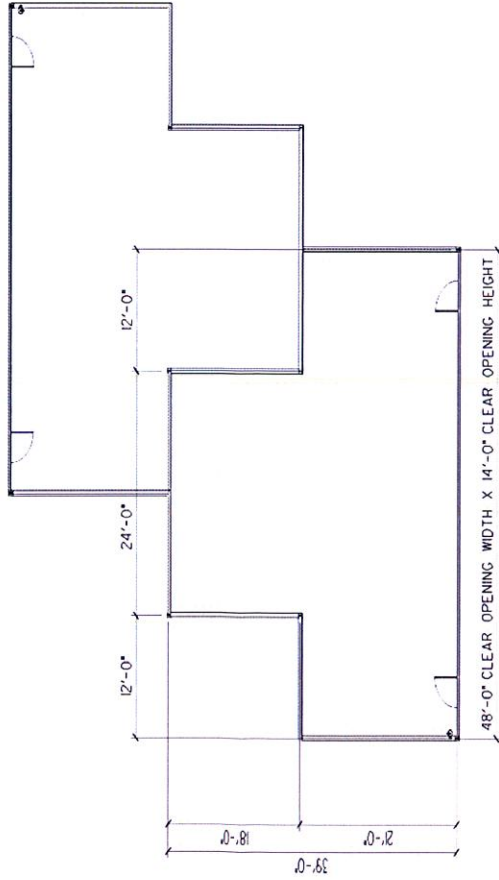





# Stanly County AIRPORT

Open T-Hangars – Constructed in 1985

Two Units – 16 total aircraft spaces  
All Occupied

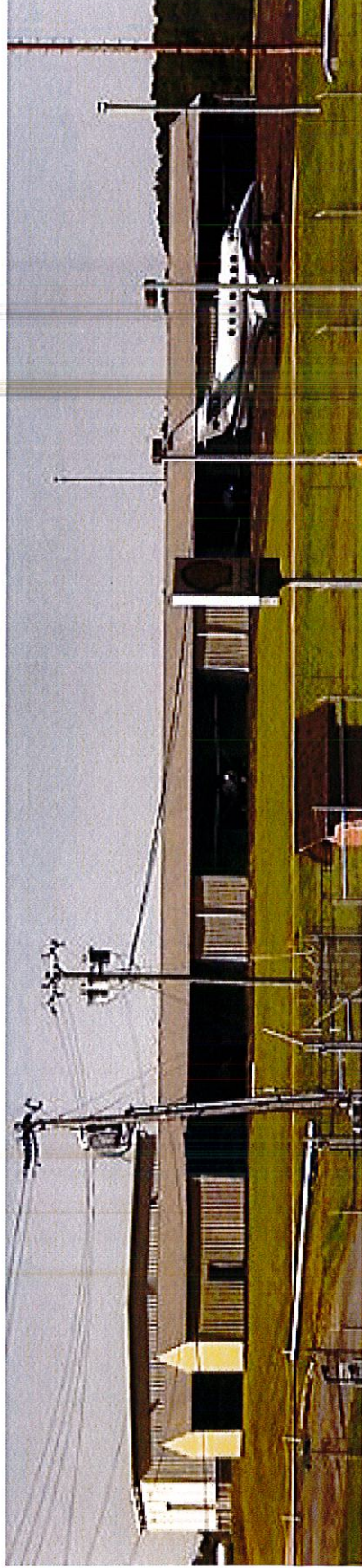

Accommodates

Up To:



Cessna 172 (Skyhawk)



Beechcraft A36 (Bonanza)



# Stanly County AIRPORT

**Main Ramp Tie-Down Spaces  
Approximately - 50, Use varies**







**Current Enclosed Hangar Waiting List – Currently 15 waiting:**

- Cessna
- Cardinal
- Cessna
- Skylane
- Aerocoupe
- RV6A
- Velocity
- Cessna
- Aeronica Champ
- Cessna
- Cessna / Cirrus
- Musketeer
- Piper 140
- Cessna
- Cessna

**(All private ownership, no corporate aircraft on present list.)**



**Where we want to be.**



# Hangar Development Community Hangar - Options

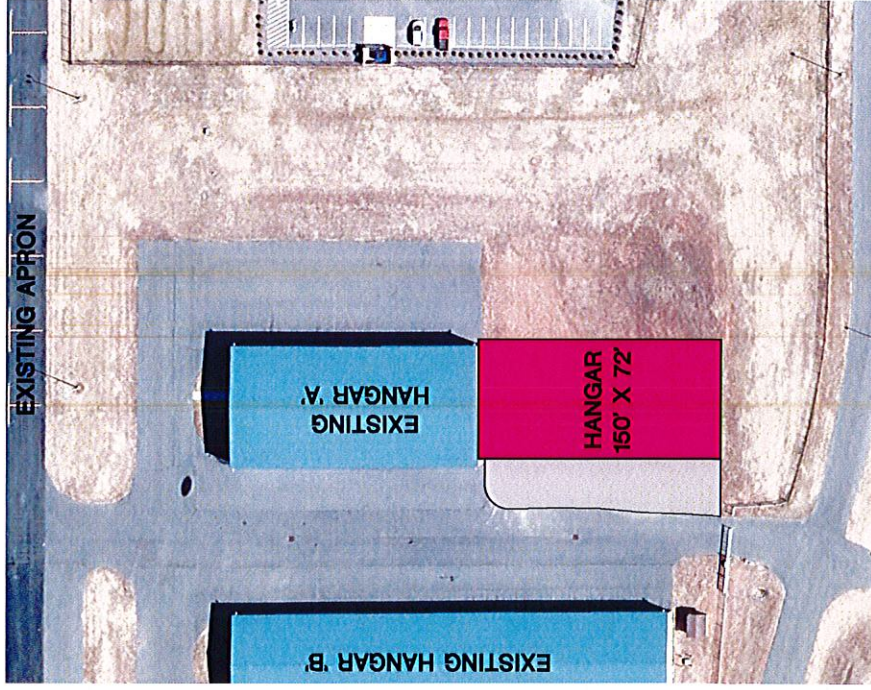

**Community Hangar – Option 1**  
**150' x 72'**

**Preliminary Cost Estimate\* - \$2,600,000**

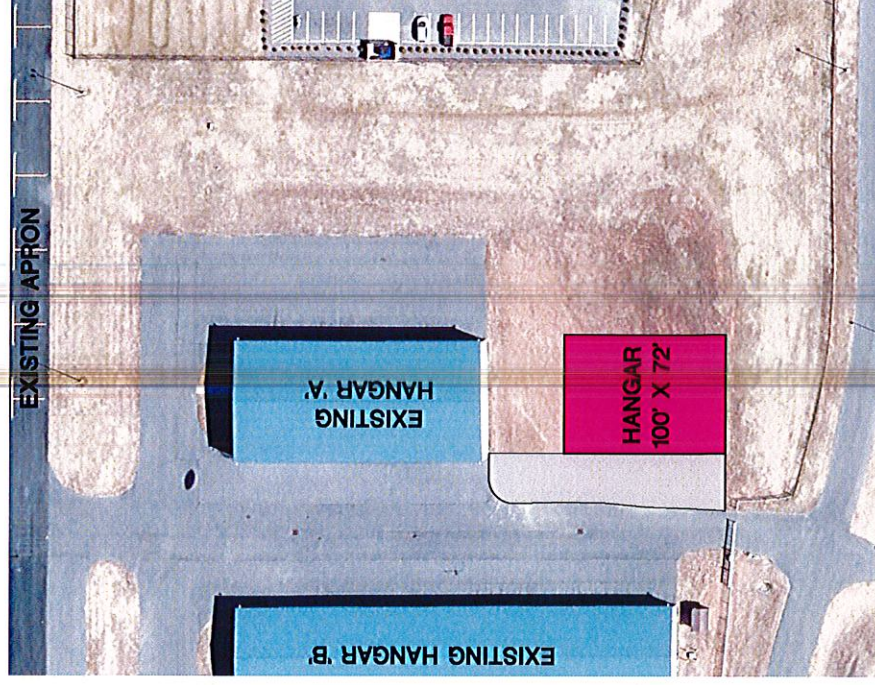

**Community Hangar – Option 2**  
**100' x 72'**

**Preliminary Cost Estimate\* - \$1,800,000**

\*Preliminary cost estimates are based on recent bid numbers from similar projects and should be used for comparison purposes only. Currently the bid market is very volatile. Final estimated cost should be developed once project design is complete.

# Community Hangar Option 1 – 150' x 72' Hangar

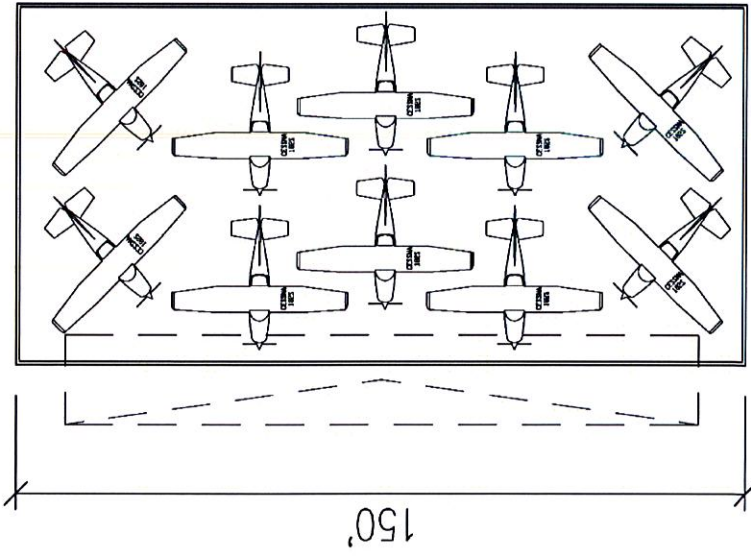

72'



Up to 10  
Cessna 172 (Skyhawk)

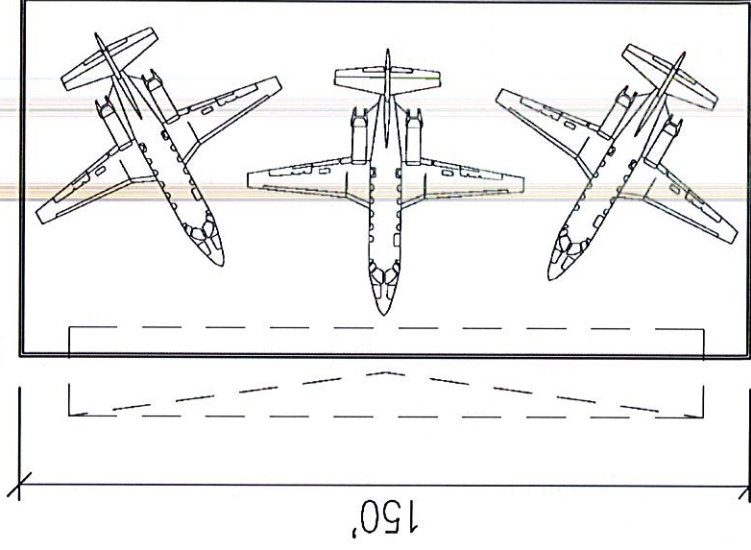

72'

Accommodates:

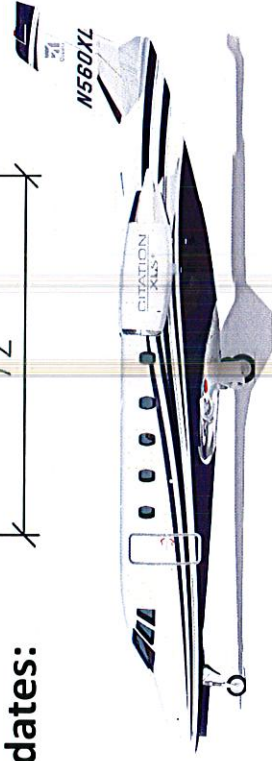

Up to 3  
Cessna Citation XLS



# Community Hangar Option 2 – 100' x 72' Hangar

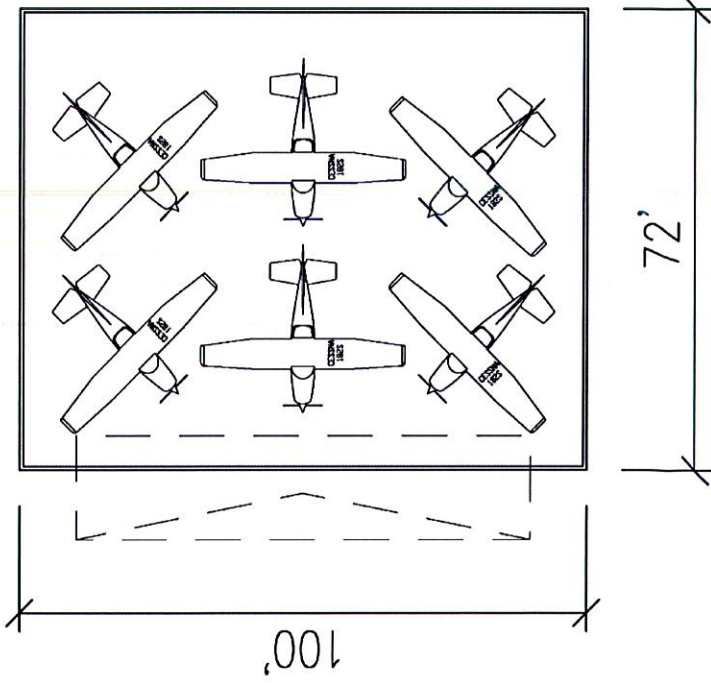

**Up to 6  
Cessna 172 (Skyhawk)**

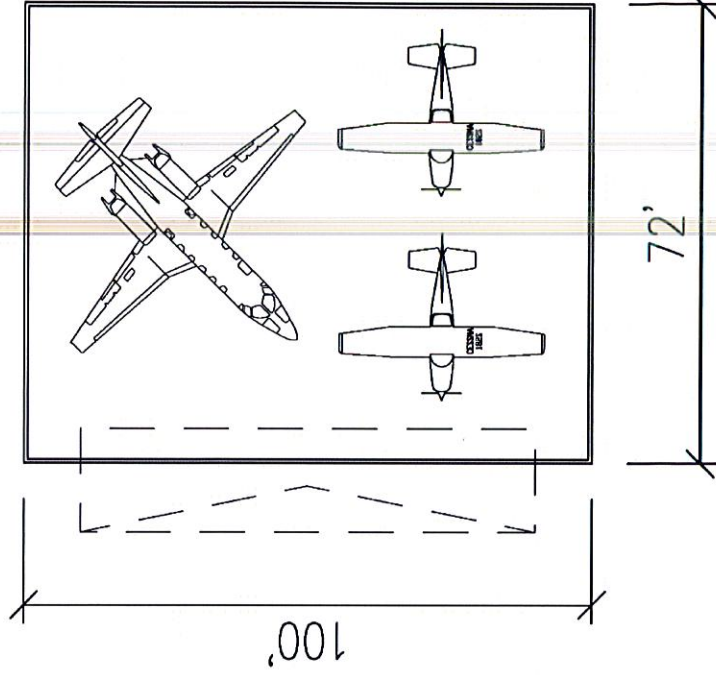

**Accommodates:**

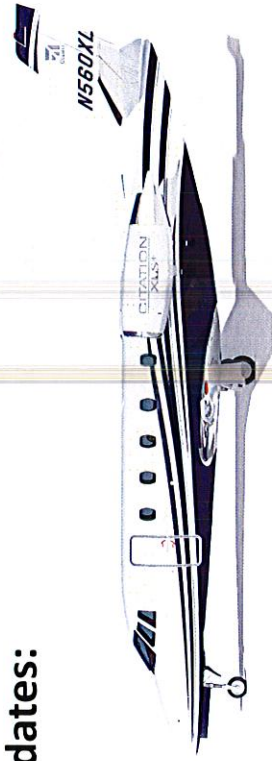

**1 - Cessna Citation XLS  
2 - Cessna 172 (Skyhawk)**



# Corporate Hangar

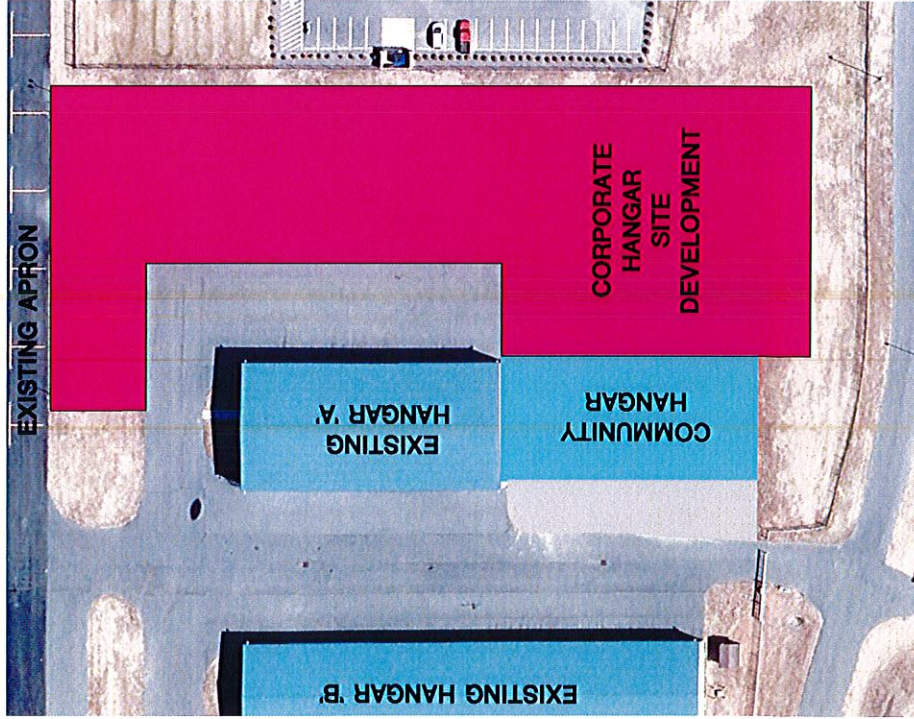

## Phase 1

### Site Development

**Preliminary Cost Estimates\* - \$900,000**

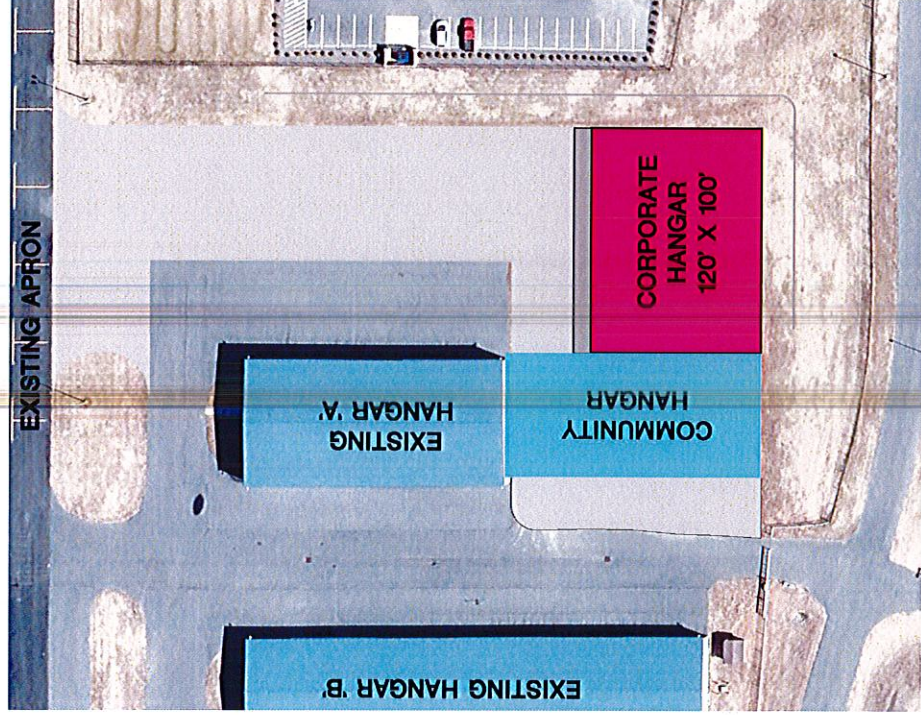

## Phase 2

### 120' x 100' Hangar

**Preliminary Cost Estimates\* - \$3,000,000**

\*Preliminary cost estimates are based on recent bid numbers from similar projects and should be used for comparison purposes only. Currently the bid market is very volatile. Final estimated cost should be developed once project design is complete.

**Corporate Hangar  
120' x 100' Hangar**

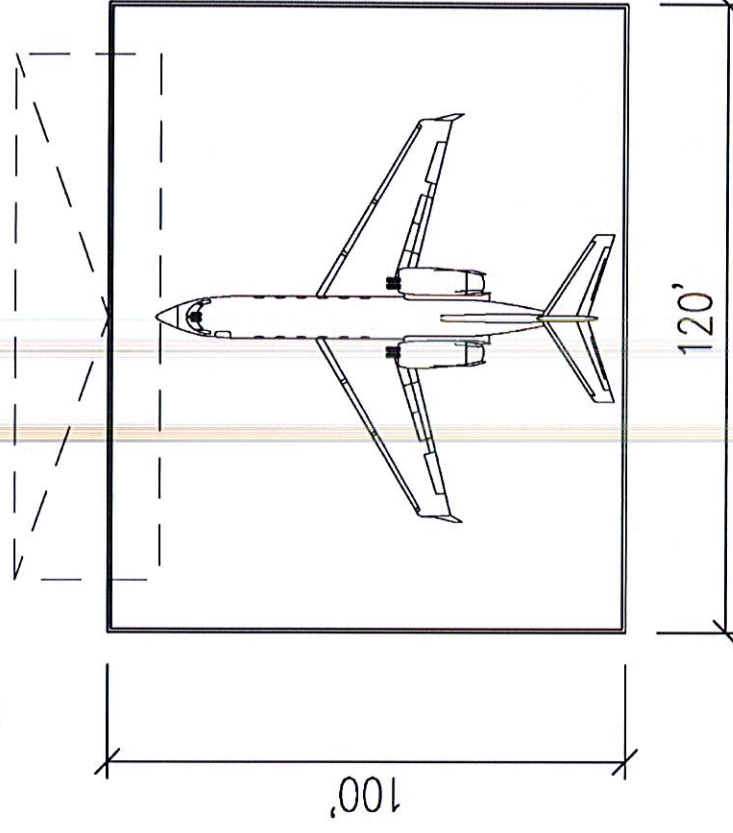
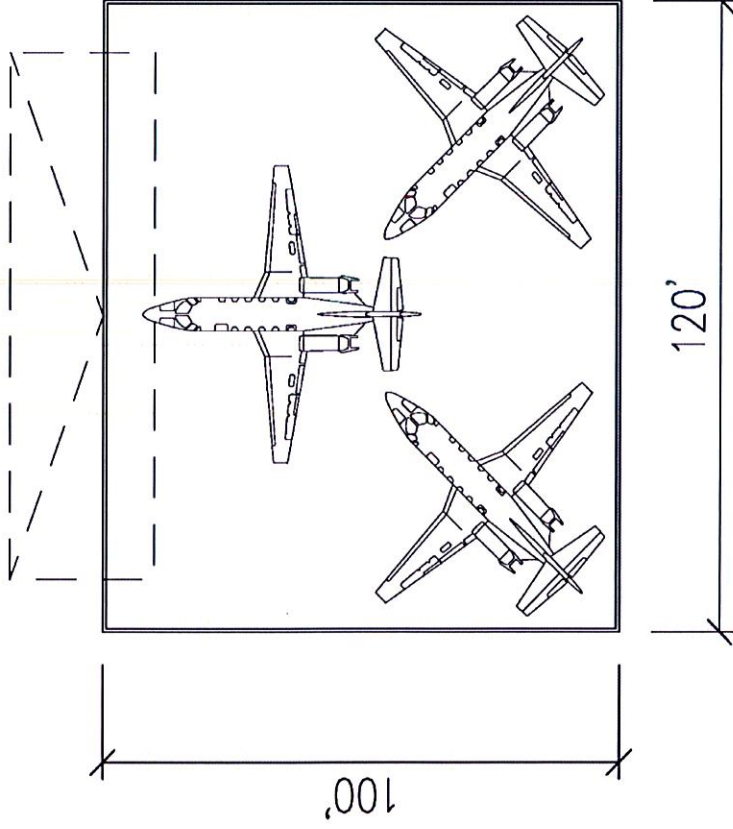

**Accommodates:**

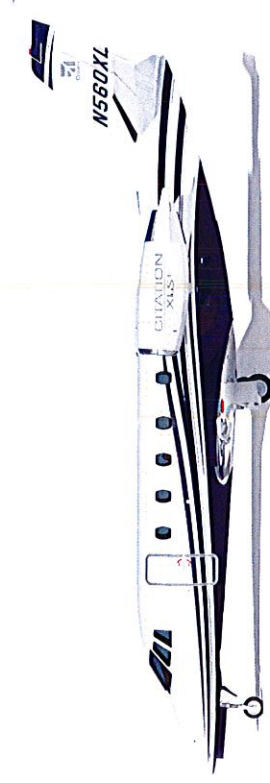

**Up to 3  
Cessna Citation XLS**

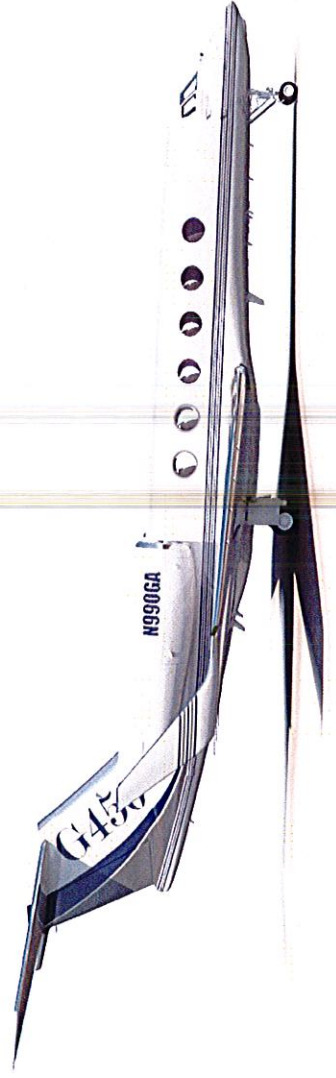

**Gulfstream G-IV**





### **Summary:**

- Request funding support for Community Hangar Option 1.
  - Option 1 allows greatest flexibility and effective use of property.
  - More square footage for reasonable additional investment.
- Move forward with design/completion of Corporate Hangar Phase 1, Site development pending funding availability.
  - Stay ahead of facility construction by having site prepped.
  - Ramp space is common use so may qualify for outside funding.
  - With site prep completed, positions airport to respond more timely if approached by entity with larger corporate aircraft or for additional need for rental hangar space for small aircraft.





**Thank you for your time and consideration of this presentation.**

**Regards,  
The Stanly County Airport Authority**



# Stanly County Board of Commissioners

Meeting Date: October 2, 2017

Presenter: Andy Lucas

\_\_\_\_\_ | 5A  
 Consent Agenda | Regular Agenda

Presentation Equipment:  Lectern PC\*  Lectern VCR  Lectern DVD  Document Camera\*\*  Laptop\*\*\*

Please Provide a Brief Description of your Presentations format: \_\_\_\_\_

\* PC is equipped with Windows XP and Microsoft Office XP (including Word, Excel, and PowerPoint), Internet connectivity and Network connectivity for County Employees.

\*\* If you have need to use the Document Camera and zoom into a particular area, if possible please attach a copy of the document with the area indicated that you need to zoom into. A laser light is available to pinpoint your area of projection.

\*\*\* You can bring in a laptop that will allow video out to be connected at the lectern – set display to 60Mhz.

## ITEM TO BE CONSIDERED

### REGION F AGING ADVISORY COMMITTEE APPOINTMENT

Subject

Currently there are two (2) vacant Delegate positions on the RFAAC for Stanly County. Enclosed is a volunteer application for Mr. William “Bill” Rigsbee that was recently received. If approved, the appointment would be for a two (2) year term which would expire June 30, 2019.

Requested Action

Request the Board appoint Mr. Rigsbee as a Delegate to represent Stanly County on the RFAAC for a two (2) year term which will expire June 30, 2019.

Signature: \_\_\_\_\_

Dept. \_\_\_\_\_

Date: \_\_\_\_\_

Attachments: Yes \_\_\_\_\_ No    x   

#### Review Process

#### Certification of Action

Approved		Initials
Yes	No	
_____	_____	
_____	_____	
_____	_____	
_____	_____	
_____	_____	

Certified to be a true copy of the action taken by the Stanly County Board of Commissioners on

Finance Director

Budget Amendment Necessary

County Attorney

County Manager

Other:

\_\_\_\_\_  
 Tyler Brummitt, Clerk to the Board      Date



# Stanly County Board of Commissioners

Meeting Date: October 2, 2017  
 Presenter: Andy Lucas

   -    | **5B**  
 Consent Agenda | Regular Agenda

Presentation Equipment:  Lectern PC\*  Lectern VCR  Lectern DVD  Document Camera\*\*  Laptop\*\*\*  
 Please Provide a Brief Description of your Presentations format: \_\_\_\_\_

\* PC is equipped with Windows XP and Microsoft Office XP (including Word, Excel, and PowerPoint), Internet connectivity and Network connectivity for County Employees.  
 \*\* If you have need to use the Document Camera and zoom into a particular area, if possible please attach a copy of the document with the area indicated that you need to zoom into. A laser light is available to pinpoint your area of projection.  
 \*\*\* You can bring in a laptop that will allow video out to be connected at the lectern – set display to 60Mhz.

## ITEM TO BE CONSIDERED

### NORWOOD ABC BOARD APPOINTMENT

**Subject**

Please see the attached correspondence from the Town of Norwood ABC Board regarding the resignation of Mr. Chalmers Glenn. Mr. Glenn has asked not to be reappointed once his term expires in November 2017. It is requested the Board appoint a replacement to serve as county representative for a three (3) year term expiring November 30, 2020.

There are no volunteer applications on file.

**Requested Action**

Request the Board appoint a member to the Town of Norwood ABC Board for a three (3) year term until November 30, 2020.

Signature: \_\_\_\_\_

Date: \_\_\_\_\_

Dept. \_\_\_\_\_

Attachments: Yes \_\_\_\_\_ No   x  

#### Review Process

#### Certification of Action

Approved  
 Yes No Initials

Certified to be a true copy of the action taken by the Stanly County Board of Commissioners on

Finance Director \_\_\_\_\_

Budget Amendment Necessary \_\_\_\_\_

County Attorney \_\_\_\_\_

County Manager \_\_\_\_\_

Other: \_\_\_\_\_

\_\_\_\_\_

\_\_\_\_\_  
 Tyler Brummitt, Clerk to the Board Date





Tyler Brummitt <tbrummitt@stanlycountync.gov>

---

## Norwood ABC Board Resignation

---

Carmen Salmon <carmen.salmon@norwoodgov.com>

Thu, Sep 7, 2017 at 2:00 PM

To: tbrummitt@stanlycountync.gov

Tyler,

Mr. Chalmers Glenn brought the attached letter to the Norwood Town Hall stating his intent to resign once his appointment expires November 2017.

Please let me know if you need any additional information or if there is anything else we need to do.

Thank you.

Carmen

*Carmen L. Salmon*

*Assistant Town Clerk & Finance Department*

*Town of Norwood*

PO Box 697

116 South Main Street

Norwood, NC 28128

Phone: (704) 474-3416

Fax: (704) 474-3201

[www.norwoodgov.com](http://www.norwoodgov.com)



**Chalmers Glenn Resignation.pdf**

8K

# Norwood ABC Board

P.O. Box 547  
Norwood, NC 28128  
(704) 474-4120

---

September 5, 2017

---

Town of Norwood Commissioners,

I do not wish to be re-appointed as County Representative to the Norwood ABC Board when my appointment expires on November 2017.

I have enjoyed serving the board for the past few years.

Sincerely,

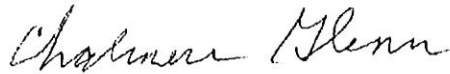

Chalmers Glenn

---

cc: Stanly County Commissioners



# Stanly County Board of Commissioners

Meeting Date: October 2, 2017

Presenter: Andy Lucas

Consent Agenda

Regular Agenda

Presentation Equipment:  Lectern PC\*  Lectern VCR  Lectern DVD  Document Camera\*\*  Laptop\*\*\*

Please Provide a Brief Description of your Presentations format: \_\_\_\_\_

\* PC is equipped with Windows XP and Microsoft Office XP (including Word, Excel, and PowerPoint), Internet connectivity and Network connectivity for County Employees.

\*\* If you have need to use the Document Camera and zoom into a particular area, if possible please attach a copy of the document with the area indicated that you need to zoom into. A laser light is available to pinpoint your area of projection.

\*\*\* You can bring in a laptop that will allow video out to be connected at the lectern – set display to 60Mhz.

## ITEM TO BE CONSIDERED

### "THANK YOU FOR YOUR SERVICE" DAY PROCLAMATION

**Subject**  
Please see the attached proclamation recognizing Tuesday, November 7, 2017 as "Thank You For Your Service" Day.

**Requested Action**  
Request Board approval of the proclamation.

Signature: \_\_\_\_\_

Dept. \_\_\_\_\_

Date: \_\_\_\_\_

Attachments: Yes \_\_\_\_\_ No   x  

#### Review Process

#### Certification of Action

	Approved		Initials
	Yes	No	
Finance Director	—	—	
Budget Amendment Necessary	—	—	
County Attorney	—	—	
County Manager	—	—	
Other:	—	—	

Certified to be a true copy of the action taken by the Stanly County Board of Commissioners on

\_\_\_\_\_  
Tyler Brummitt, Clerk to the Board      Date





*SUZANNE W. LOWDER*  
*REGISTER OF DEEDS*

---

---

**PROCLAMATION**  
**“THANK YOU FOR YOUR SERVICE” DAY**  
**NOVEMBER 7, 2017**

---

---

**WHEREAS**, the Stanly County Register of Deeds encourages all Veterans to record their Active Duty Discharge Forms (DD form 214) and in return the Register of Deeds will issue a Veterans “Thank You for Your Service” photo ID Card that allows the Veteran to receive discounts, free services or incentives from participating Stanly County businesses; and

**WHEREAS**, the Stanly County Board of Commissioners encourages businesses to participate in this program as a means of showing their continued support and appreciation for our local veterans for the sacrifices they made on our behalf; and

**NOW THEREFORE, BE IT RESOLVED** by the Board of Commissioners for Stanly County; That Tuesday, November 7, 2017 shall be recognized as Veterans “Thank You for Your Service Day”.

Please join us in the lobby of the Stanly County Commons, 1000 North First Street, from 9:00 am until 3:00 pm to celebrate and honor our Veterans.

Adopted this the 2nd day of October, 2017.

---

W. D. Lawhon, Jr., Chairman  
Board of County Commissioners



# Stanly County Board of Commissioners

Meeting Date: October 2, 2017  
 Presenter: Chairman Lawhon

7

Consent Agenda | Regular Agenda

Presentation Equipment:  Lectern PC\*  Lectern VCR  Lectern DVD  Document Camera\*\*  Laptop\*\*\*  
 Please Provide a Brief Description of your Presentations format: \_\_\_\_\_

\* PC is equipped with Windows XP and Microsoft Office XP (including Word, Excel, and PowerPoint), Internet connectivity and Network connectivity for County Employees.

\*\* If you have need to use the Document Camera and zoom into a particular area, if possible please attach a copy of the document with the area indicated that you need to zoom into. A laser light is available to pinpoint your area of projection.

\*\*\* You can bring in a laptop that will allow video out to be connected at the lectern – set display to 60Mhz.

## ITEM TO BE CONSIDERED

<b>Subject</b>	<p><b>CONSENT-AGENDA</b></p> <p>A. Minutes – Regular meeting of September 5, 2017.</p> <p>B. Finance – Request acceptance of the Monthly Financial Report For Two Months Ended August 31, 2017.</p> <p>C. Sheriff’s Office – Request approval of budget amendments # 2018-05 &amp; 2018-06.</p>
<b>Requested Action</b>	<p>Request approval of the above items as presented.</p>

Signature: _____	Dept. _____
Date: _____	Attachments: Yes No ___x_
<b>Review Process</b>	
Approved	
	Yes No Initials
Finance Director	___ ___
Budget Amendment Necessary	___ ___
County Attorney	___ ___
County Manager	___ ___
Other:	___ ___
<b>Certification of Action</b>	
Certified to be a true copy of the action taken by the Stanly County Board of Commissioners on	
_____	
Tyler Brummitt, Clerk to the Board	Date

**STANLY COUNTY  
BOARD OF COMMISSIONERS  
REGULAR MEETING MINUTES  
SEPTEMBER 5, 2017**

**COMMISSIONERS PRESENT:** Bill Lawhon, Chairman  
Joseph Burleson, Vice Chairman  
Scott Efird  
Janet K. Lowder  
Gene McIntyre  
Ashley Morgan  
Matthew Swain

**COMMISSIONERS ABSENT:** None

**STAFF PRESENT:** Andy Lucas, County Manager  
Jenny Furr, County Attorney  
Tyler Brummitt, Clerk

**CALL TO ORDER**

The Stanly County Board of Commissioners (the "Board") met in regular session on Tuesday, September 5, 2017 in the Commissioners Meeting Room, Stanly Commons. Chairman Lawhon called the meeting to order at 7:00 p.m., gave the invocation and led the pledge of allegiance.

**APPROVAL / ADJUSTMENTS TO THE AGENDA**

Commissioner McIntyre moved to approve the agenda with the amended State Board of Education resolution as item # 13. Commissioner Morgan seconded the motion which passed by unanimous vote. Commissioner Swain than requested budget amendment # 2018-04 for Senior Services be added as item # 14 (E) on the consent agenda. Commissioner Lowder seconded the motion which also passed by unanimous vote.

**ITEM # 1 – RED RIBBON WEEK PROCLAMATION**

**Presenter: Vice Chairman Burleson**

For Board consideration, Vice Chairman Burleson read the proclamation then moved to have it approved. The motion was seconded by Commissioner Lowder and carried by a 7 – 0 vote.

**See Exhibit A**

**STANLY COUNTY BOARD OF COMMISSIONERS  
DECLARES OCTOBER 23 – 31, 2017 AS RED RIBBON WEEK**



## **ITEM # 2 – PLANNING & ZONING – ZA 17-05- REZONING REQUEST FOR CASEY AMMONS**

**Presenter: Michael Sandy, Planning Director**

Casey Ammons submitted a request to rezone an approximately 1.87 acre lot owned by Jeffrey Wayne Mills on the southeast corner of Webb Road and NC 200 Highway South (Tax Record 138483) in Stanfield from RA (Residential Agricultural) to M-1 (Light Industrial). Mr. Ammons intends to use the lot for a vehicle repair shop and plans to construct a building for this purpose. Because M-1 district allows for up to 5 vehicles to be stored outside and GB district does not, Mr. Ammons requested the property be rezoned to M-1. He plans to store the vehicles in a fenced in area.

After a brief period of questions from the Board, Chairman Lawhon declared the public hearing open. During this time, Mr. Ammons spoke in favor of the request noting that he has been in the auto repair business for 10 years, 5 of which have most recently been in Stanly County. With no one else coming forward to speak, the hearing was closed.

By motion, Vice Chairman Burluson moved to approve the rezoning request and was seconded by Commissioner McIntyre. The motion carried with a 7 – 0 vote.

## **ITEM # 3 – PRESENTATION ON THE DEVELOPMENT OF A STATEWIDE PUBLIC TRANSPORTATION STRATEGIC PLAN ON BEHALF OF THE NCDOT**

**Presenter: Candice Moffitt, Transportation Services Director**

On behalf of the NC DOT's Public Transportation Division, Ms. Moffitt gave a presentation regarding NC DOT's development of the statewide public transportation strategic plan noting that the presentation was to inform and engage local elected officials. The purpose of the plan is to help public transit systems keep pace with projected growth through improved partnerships and recommendations for strategic transit investments that will build on the success of the state's current system. Due to the expected population increase in metropolitan areas and in smaller communities over the next 20 + years, it is crucial that North Carolina's public transportation system be able to connect residents in urban and rural areas to opportunities and services such as jobs, higher education, healthcare and recreation. Ms. Moffitt noted that any feedback or comments received from the Board will be delivered during the community meeting on October 16<sup>th</sup>. After the presentation, Ms. Moffitt entertained questions from the Board.

No action was required from the Board.

## **ITEM # 4 – DENTAL CLINIC PRESENTATION**

**Presenter: Dr. Mindy Turner, Pediatric Dentist**

At Chairman Lawhon's request, Dr. Turner provided an overview of the Dental Clinic's programs and the services offered. Dr. Turner stated that the clinic was started fifteen (15) years ago for patients between the ages of 0 – 19 and provides services which include cleanings, extractions, xrays, fillings, crowns, etc. Included in the presentation was a list of the staff who serve in the clinic, revenue sources, local accomplishments, collaboration partners, and future projects planned for the clinic. It was noted that the clinic is a cost neutral program which requires no county dollars for operation with all expenses being covered by the revenues generated within the clinic or through grant monies received. The County does provide the space and administrative support for the clinic. Dr. Turner ended by expressing her appreciation to all the individuals and organizations that support the clinic's various programs. She then entertained questions from the Board.

No additional action was taken.

#### **ITEM # 5 – STANLY COUNTY UTILITIES**

**Presenter: Donna Davis, Utilities Director**

##### **A. Authorization to apply funding through the NC DEQ/DWI for a State Water Grant and approval of the associated resolution**

Ms. Davis noted that the County intends to apply to the NC Department of Environmental Quality (NC DEQ) Division of Water Infrastructure (DWI) for a State Water Grant to construct and install 2 trihalomethane removal and supplemental chlorine injection systems in problematic areas of the water distribution system. Ms. Davis sought Board approval to submit the application as well as approval of the associated application resolution.

Commissioner Swain moved to approve the funding application and associated resolution as requested. The motion was seconded by Vice Chairman Burleson which passed by unanimous vote.

**See Exhibit B**

#### **RESOLUTION BY GOVERNING BODY OF APPLICANT**

##### **B. Request approval of attached changes to the Utilities Department policies**

It was requested the Board approve the following changes to the Stanly County Utilities policies:

1. Document: Utility System Rules & Regulations – Section 9: Disconnection of Service for Nonpayment
2. Document: Utility Rate System Rules & Regulations – Section 15: Billing Adjustments
3. Document: Stanly County Water Main Extension Policy – Reimbursable Programs



By motion Vice Chairman Burleson moved to approve all policy changes as requested. The motion was seconded by Commissioner McIntyre and carried by unanimous vote.

**C. Stanly County Utilities Language Access Plan (LAP)**

Ms. Davis stated that the USDA now requires that a LAP be in place for entities who receive USDA funds. Since Stanly County is a recipient of these funds for the West Stanly Wastewater Treatment Plant, it was requested the Board review and approve the attached Stanly County Utilities Language Access Plan. It was noted that the LAP presented is also consistent with the Stanly County LAP approved by the Board in September 2012 and the Greater Badin Water & Sewer District in January 2017.

Vice Chairman Burleson moved to approve the LAP as presented and was seconded by Commissioner McIntyre. The passed with a 7 – 0 vote.

**See Exhibit C  
Language Access Plan  
Stanly County Utilities  
Stanly County, NC**

**ITEM # 6 – GREATER BADIN WATER & SEWER DISTRICT (GBWSD)**

**Presenter: Donna Davis, Utilities Director**

Prior to the presentation, Vice Chairman Burleson moved to recess the meeting of the Board of County Commissioners and convene as the Great Badin Water & Sewer District Board of Governors (GBWSD) The motion was seconded by Commissioner Swain and passed by unanimous vote.

For Board consideration, Ms. Davis presented the airport sewer project's Assignment of Easements and Rights of Way for Sanitary Sewer Lines and Facilities in which GBWSD grants its easements to the County of Stanly. The Deed of Easement signed by the individual property owner(s) granted the easements to the GBWSD, but the County is technically the entity that needs them. The document presented conveyed one (1) permanent easement and one (1) temporary easement which are necessary for the construction/maintenance of the airport sewer lines.

By motion, Vice Chairman Burleson moved to approve the Assignment of Easements and Rights of Way for Sanitary Sewer Lines and Facilities. The motion was seconded by Commissioner Morgan and carried by unanimous vote.



Commissioner McIntyre then moved to recess the meeting of the GBWSD and reconvene as the Board of county Commissioners. The motion was seconded by Commissioner Swain and passed with the 7 – 0 vote.

#### **ITEM # 7 – HUMAN SERVICES CONSOLIDATION**

**Presenter: Andy Lucas, County Manager**

The Board previously discussed the consolidation of the County's health and social services departments into one (1) agency, has reviewed the information from the UNC School of Government, analyzed data from other counties, evaluated the governance options available and held a public hearing on August 7, 2017 to comply with statute requirements.

For Board consideration, a resolution authorizing the consolidation and directing the existing Board of Health and Department of Social Services to make nominations to the new consolidated Health and Human Services Board by October 20, 2017 was presented.

With no comments, Commissioner Morgan moved to approve the resolution as presented. The motion was seconded by Commissioner Swain.

Prior to the vote, Commissioner McIntyre noted that while he understands there are certain aspects of the consolidation which are beneficial, he has concerns that there have been three limited discussions on the issue with nothing specific related to Option 2 discussed (if that's the option selected) to determine where it may lead, how it will be organized, the number of members on the joint board, etc. and therefore cannot support it.

Commissioner Lowder echoed Commissioner McIntyre's comments adding that the concerns expressed by those who spoke during the public hearing have not yet been addressed and feels they need to be prior to making a decision.

Chairman Lawhon recognized Larry Faulkner, Chairman of the Board of Health. Mr. Faulkner noted that Commissioners McIntyre and Lowder have both served on the Board of Health and understand how the health department functions. He commended Health Director Joyner and Pediatric Dentist Dr. Turner on the excellent job they do. He expressed concerns with combining the boards into one large board which will result in longer meetings and feels it will make it less effective overall.

With no further discussion, Chairman Lawhon called for a vote on the motion to approve the resolution to consolidate the County's health and social services functions into one (1) agency with a separate Human Services governing Board. The motion passed by a 4 – 3 vote.

Ayes: Chairman Lawhon, Vice Chairman Burluson, Commissioner Morgan and Commissioner Swain.

Nos: Commissioner Efirm, Commissioner Lowder and Commissioner McIntyre.

**See Exhibit D**

**RESOLUTION APPROVING THE CREATION OF A CONSOLIDATED HUMAN SERVICES AGENCY  
IN ACCORDANCE WITH NC GENERAL STATUTE 153A-77**

**ITEM # 8 – EMERGENCY RADIO SYSTEM FOLLOW-UP**

**Presenters: Andy Lucas, County Manager**

**Brian Simpson, Emergency Services Director**

For Board information, the County Manager and EMS Director provided a follow-up presentation concerning the radio system and coverage issues being experienced in the eastern portion of the County. The County Manager noted that the system is fully operational with 95% percent on-street coverage and that feedback on the system has been overwhelmingly positive from first responders.

To address coverage issues in eastern Stanly County, staff has evaluated various options including building or leasing a fifth (5<sup>th</sup>) tower site, experimented with DVRS technology and the development of a potential patch for the VIPER system at Buck Mountain in Montgomery County. The County Manager provided detailed information for each option including cost, potential drawbacks and/or any concerns.

As the proposed next step, staff will continue to analyze the feasibility of a VIPER patch at Buck Mountain while continuing to evaluate the cost and feasibility of tower site locations, continue to track issues and work closely with radio system partners to identify solutions. An update will be provided at the Board’s retreat in February.

County Manager Lucas and EMS Director Simpson entertained questions with no further action required.

**RECESS**

Chairman Lawhon called for a short recess at 8:53 p.m. The meeting was reconvened at 8:29 p.m.

**ITEM # 9 – LOCUST FIREWORKS APPROVAL**

**Presenter: Andy Lucas, County Manager**



The City of Locust requested approval of a fireworks display on Saturday, September 16<sup>th</sup> at approximately 9:00 p.m. as part of a civic event sponsored by the city.

Commissioner McIntyre moved to approve the request and was seconded by Commissioner Lowder. The motion carried unanimously.

#### **ITEM # 10 – STANLY COUNTY – LOCUST WATER DISTRIBUTION SUBCOMMITTEE**

**Presenter: Andy Lucas, County Manager**

The City of Locust has requested the County explore opportunities to partner or collaborate with them on the provisions of public water services. Staff recommended a subcommittee of the Board be designated to meet with staff and representatives from the City of Locust to learn more about their issues, concerns and future plans. The Board did not appoint a formal committee but agreed by consensus to allow two (2) members of the Board to informally meet with the City of Locust officials.

Vice Chairman Burleson and Commissioner Swain volunteered to meet with the City of Locust officials along with the County Manager.

#### **ITEM # 11 – BOARD & COMMITTEE APPOINTMENTS**

**A. Department of Social Services - Presenter: Tammy Schrenker, DSS Director**

Current DSS Board member Nancy Smoak's term expired on June 30, 2017. She has served one (1) term and agreed to serve again if reappointed. It was requested the Board consider reappointing Ms. Smoak for a three (3) year term until June 30, 2020.

Commissioner Efird moved to reappoint Ms. Smoak as requested. The motion was seconded by Commissioner Lowder and passed unanimously.

**B. JURY COMMISSION - Presenter: Andy Lucas, County Manager**

Due to current commission member Paul Carpenter's term expiring on June 30, 2017, it was requested the Board appoint a new member as his replacement. Mr. Carpenter requested not to be reappointed after having served two (2) consecutive terms.

Commissioner Swain moved to appoint William Efird. The motion was seconded by Vice Chairman Burleson and carried by a 7 – 0 vote.

**C. REGION F AGING ADVISORY COMMITTEE - Presenter: Andy Lucas, County Manager**



With Janice Abernathy's term having expired on June 30, 2017, RFAAC requested the Board appoint a representative for Stanly County. Ms. Abernathy has agreed to serve as an Alternate since she is unable to serve again as a Delegate after having served three (3) consecutive terms.

Vice Chairman Burleson moved to appoint Ms. Abernathy as an Alternate on the committee to serve until June 30, 2018. His motion was seconded by Commissioner McIntyre and passed by unanimous vote.

---

**ITEM # 12 – SHERIFF'S OFFICE- INCENTIVE PAY FOR SWAT & K-9 PERSONNEL****Presenter: Commissioner Morgan**

Earlier this year, the Board discussed incentive pay for voluntary duty assignments of K-9 and SWAT personnel. The Board agreed by consensus to allow the Sheriff to provide incentive pay for special duty assignments at the Sheriff's discretion. The Board further agreed the funding for these incentives and any other pay increases for the Sheriff's Office personnel would be distributed by the Sheriff's Office in lieu of the annual merit allocation provided to County departments. Commissioner Morgan has since discussed this proposal with Sheriff Burris and brought it back to the Board for further discussion.

At Commissioner Morgan's request, Sheriff Burris addressed the Board. He spoke in support of the request stating that the Sheriff's Office has been in contact with several other county law enforcement offices and found that the majority of counties have incentive programs in place. He agreed that an additional incentive pay is needed and that \$7,500 (or \$500 per officer) annually is a good start and will make them more competitive with other counties. He thanked the Board for their continued support.

After a period of discussion, Vice Chairman Burleson moved to approve the additional \$7,500 and allow the Sheriff to be responsible for the distribution of merit pay for the Sheriff's Office employees. The motion was seconded by Commissioner Morgan.

For clarification, Commissioner Swain asked if the motion will allow the Sheriff to take the merit funds as a lump sum and distribute them based on employee performance plus the additional \$7500 for K-9 and SWAT bonuses. Vice Chairman Burleson replied yes and also amended his motion to state that no employee shall receive more than the maximum allowed of \$2,000 in merit pay. The County Manager noted that the funds will be distributed in January 2018 to coincide with all county departments.

Chairman Lawhon asked if the \$7,500 would be a recurring expense. Vice Chairman Burleson responded that in order for it to continue it would need to be considered again as part of the

budget next year. The County Manager added that a budget amendment will also need to be approved since the additional \$7,500 was not included in the adopted budget.

With a motion and second, Chairman Lawhon called for a vote. The motion passed by unanimous vote.

#### **ITEM # 13 – STATE BOARD OF EDUCATION RESOLUTION**

##### **Presenter: Commissioner Lowder**

Commissioner Lowder read the resolution followed by a motion to adopt it as presented.

Commissioner McIntyre seconded the motion.

Prior to the vote, Commissioner Morgan stated that he feels the resolution is premature and that the school board has not had enough time to discuss the issue.

Commissioner Lowder responded that the State Board of Education is already aware of the alleged incident which has also been reported by the media. The resolution simply requests the state promptly review the allegations and that she cannot support a “wait and see” strategy.

Vice Chairman Burleson reiterated Commissioner Morgan’s comments adding that the school board only became aware of the alleged incident on May 30<sup>th</sup> and feels it would be premature to adopt the resolution and that the school board should be allowed to do their job.

Commissioner McIntyre stated that the resolution is not directed at the local school board and does not accuse anyone but feels the allegations need to be put to rest.

Chairman Lawhon noted that personnel matters can take a long time to resolve and since the school board is meeting tonight, he prefers to wait and see the results from that meeting and would rather table the resolution for now.

With a motion and second on the floor to approve the resolution and sent it to the State Board of Education, Chairman Lawhon called for a vote. The motion failed 5 – 2.

Nos: Chairman Lawhon, Vice Chairman Burleson, Commissioner Efirm, Commissioner Morgan and Commissioner Swain.

Ayes: Commissioner Lowder and Commissioner McIntyre.

Vice Chairman Burleson then moved to table the resolution for further consideration at a later date. Commissioner Morgan seconded the motion.



For clarification, Commissioner Swain asked the County Attorney if the resolution could be tabled and brought up for discussion at a later date. According to parliamentary procedure, the County Attorney stated that a motion to reconsider can be made by a member of the prevailing vote during the same meeting but cannot be tabled until a later date. With that, Vice Chairman Burleson withdrew the motion.

#### **ITEM # 14 – CONSENT AGENDA**

**Presenter: Chairman Lawhon**

- A. Minutes – Regular meeting of August 7, 2017.
- B. Elections – Request approval to surplus & sell modified voting booths through GovDeal and have any proceeds from the sale applied towards the purchase of table-top voting screens.
- C. IT Dept. – Request approval of the attached revision to the Information Security Policy.
- D. Finance – Request approval of the attached vehicle tax refunds
- E. Senior Services – Budget amendment # 2018-04.

Commissioner McIntyre moved to approve the consent agenda as presented and was seconded by Commissioner Swain. The motion passed by unanimous vote.

**PUBLIC COMMENT** – None.

#### **BOARD COMMENTS, ANNOUNCEMENTS & COMMITTEE REPORTS**

Commissioner Efird thanked the Board for their approval of the City of Locust fireworks display.

Vice Chairman Burleson asked everyone to remember the victims of Hurricane Harvey in Texas.

Commissioner Lowder reminded everyone that with school recently starting back to please be mindful and look out for school buses.

Commissioner Swain thanked all those involved in putting together the opioid/drug abuse program presented recently at the Council of Governments meeting in Badin.

Chairman Lawhon read a thank you letter received from Charles Brown who was recently reappointed to the EDC board. He also provided statistics related to the increase in the number of building permits issued in August 2017 versus the same time in 2016 and that it is a sign that the economy continues to improve in the county.

**CLOSED SESSION**



Vice Chairman Burleson moved to recess the meeting into closed session in order to discuss a real estate transaction in accordance with G. S. 143-318.11(a)(5). His motion was seconded by Commissioner Morgan and carried with a 7 – 0 vote at 9:08 p.m.

**ADJOURN**

With no additional items presented for discussion, Commissioner Swain moved to adjourn the meeting. His motion was seconded by Commissioner Lowder and passed unanimously at 9:31 p.m.

---

W. D. Lawhon, Jr., Chairman

---

Tyler Brummitt, Clerk

**STANLY COUNTY  
NORTH CAROLINA**

---

**MONTHLY**

---

**FINANCIAL REPORT**

***For Two Months Ended  
August 31, 2017***



---

***Prepared and Issued by:  
Stanly County Finance Department***

**STANLY COUNTY, NORTH CAROLINA  
FISCAL YEAR 2017-2018**

---

	<b>Page</b>
<b>MONTHLY FINANCIAL REPORTS</b>	
General Fund:	
Revenue and Expense Graphic - Comparative FY 2017 with FY 2018	1
Revenue Graphic by Source - Comparative FY 2017 with FY 2018	2
Revenue Graphic by Source - Compared to Amended Budget 2018	3
Expense Graphic by Function - Comparative FY 2017 with FY 2018	4
Expense Graphic by Function - Compared to Amended Budget 2018	5
All Fund Financial Information:	
Financial information - All Operating Funds	6-9
Financial information - Project Funds	10-13
General Fund:	
Comparative Cash Position - Five years	14
Investment Report	15
General Fund:	
Fund Balance Calculation	16



## General Fund Revenues and Expenses Actual vs Budget Fiscal Year 2018

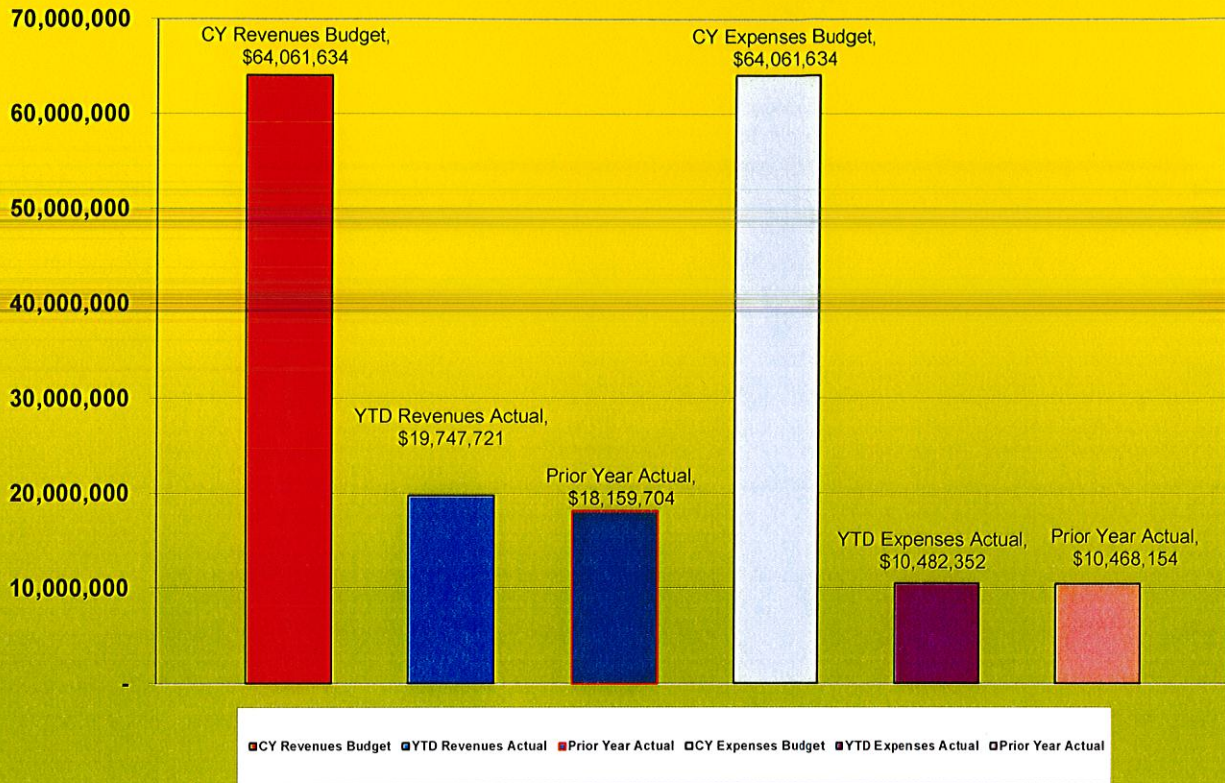



**Stanly County**  
**General Fund Revenues by Source**  
**For the Two Months Ended August 31, 2017**  
**with Comparative August 31, 2016**

REVENUES:

	<u>08/31/17</u>	<u>08/31/16</u>	<u>Variance</u>	<u>Percent</u>
Ad Valorem Taxes	\$ 16,300,856.99	\$ 14,606,619.57	\$ 1,694,237.42	111.60%
Sales Taxes	-	-	-	0.00%
Other Taxes	62,414.21	72,827.92	(10,413.71)	85.70%
Restricted Intergovernmental	755,496.50	1,308,499.15	(553,002.65)	57.74%
Licenses and Permits	164,373.85	148,984.53	15,389.32	110.33%
Sales and Services	2,005,214.38	1,826,025.02	179,189.36	109.81%
Investment Earnings	21,172.14	7,768.43	13,403.71	272.54%
Miscellaneous	<u>438,193.18</u>	<u>188,979.18</u>	<u>249,214.00</u>	<u>231.87%</u>
<b>Totals</b>	<b>\$ 19,747,721.25</b>	<b>\$ 18,159,703.80</b>	<b>\$ 1,588,017.45</b>	<b>108.74%</b>

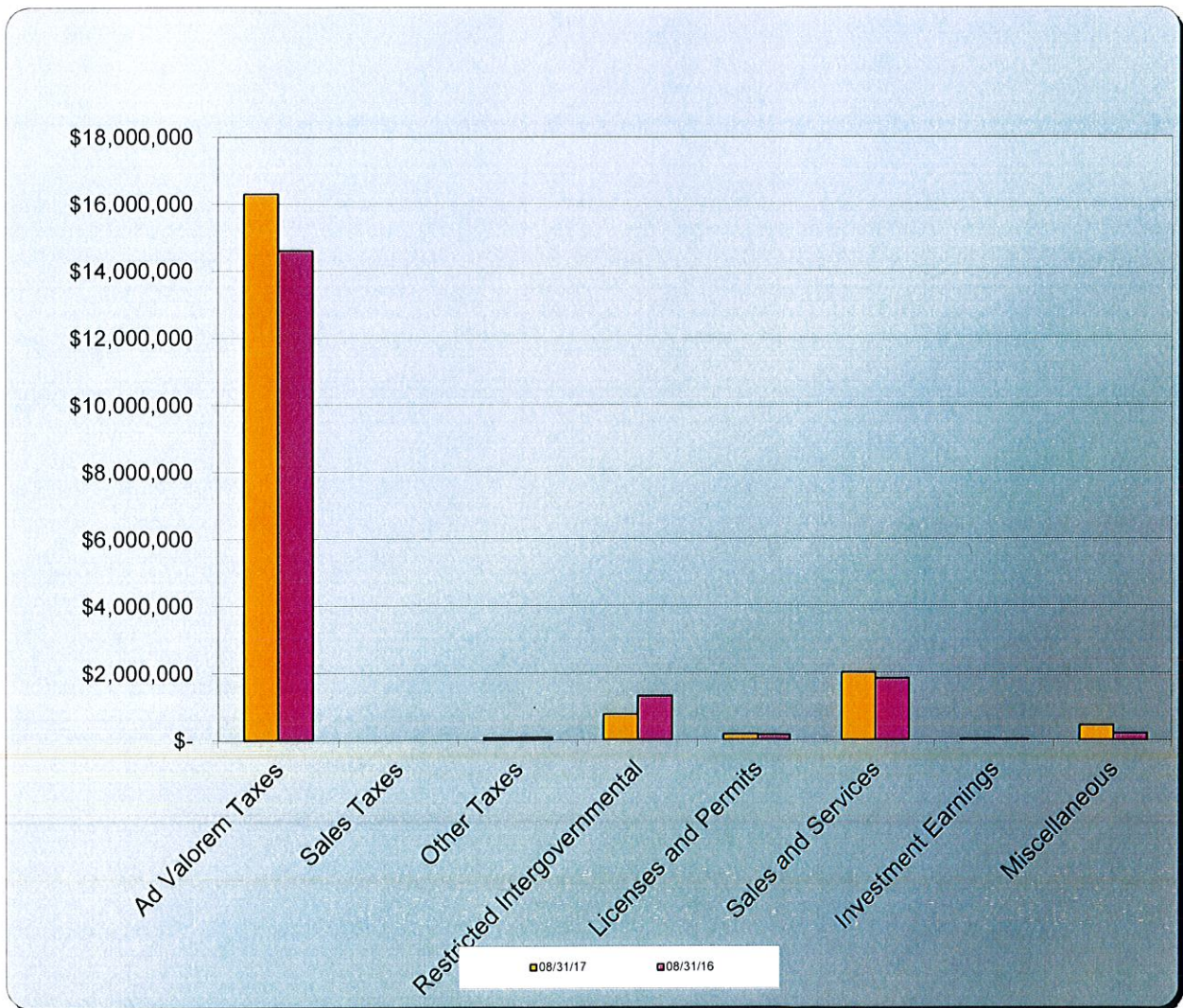



**Stanly County**  
**General Fund Budget by Source Compared to Actual Revenues**  
**For the Two Months Ended August 31, 2017**

REVENUES:	Amended Budget	Actual	Actual Over/(Under)	Percent Collected
Ad Valorem Taxes	\$ 31,958,948.00	\$ 16,300,856.99	\$ (15,658,091.01)	51.01%
Sales Taxes	9,260,000.00	-	(9,260,000.00)	0.00%
Other Taxes	646,500.00	62,414.21	(584,085.79)	9.65%
Restricted Intergovernmental	9,679,348.00	755,496.50	(8,923,851.50)	7.81%
Licenses and Permits	992,531.00	164,373.85	(828,157.15)	16.56%
Sales and Services	8,264,825.00	2,005,214.38	(6,259,610.62)	24.26%
Investment Earnings	127,500.00	21,172.14	(106,327.86)	16.61%
Miscellaneous	1,211,361.00	438,193.18	(773,167.82)	36.17%
Fund Balance Appropriated	1,920,621.00	-	(1,920,621.00)	0.00%
<b>Totals</b>	<b>\$ 64,061,634.00</b>	<b>\$ 19,747,721.25</b>	<b>\$ (44,313,912.75)</b>	<b>30.83%</b>

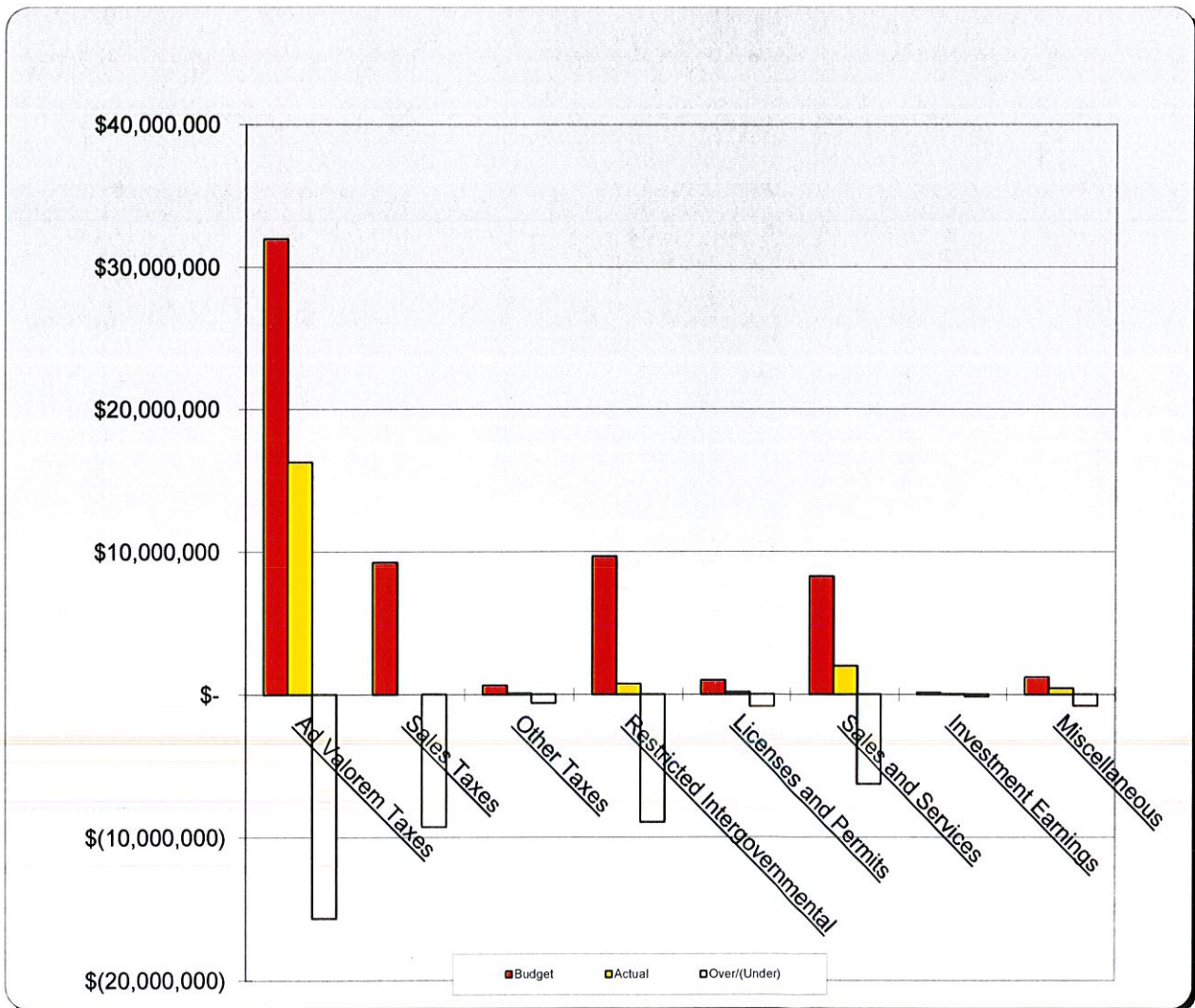



**Stanly County**  
**General Fund Expenses**  
**For the Two Months Ended August 31, 2017**  
**with Comparative August 31, 2016**

EXPENSES:

	08/31/17	08/31/16	Variance	Percent
General Government	\$ 1,175,694.85	\$ 939,103.62	\$ 236,591.23	125.19%
Public Safety	2,430,752.96	2,710,460.67	(279,707.71)	89.68%
Transportation	192,075.57	229,051.45	(36,975.88)	83.86%
Environmental Protection	128,171.57	156,589.51	(28,417.94)	81.85%
Economic and Physical Development	309,664.75	208,618.01	101,046.74	148.44%
Human Services	2,299,889.08	2,514,834.72	(214,945.64)	91.45%
Education	2,934,307.41	2,563,676.01	370,631.40	114.46%
Culture and Recreation	277,085.26	262,217.53	14,867.73	105.67%
Debt Service	709,710.33	852,352.50	(142,642.17)	83.26%
Special Appropriations	25,000.00	31,250.00	(6,250.00)	80.00%
Transfers and Contingency	-	-	-	0.00%
<b>Totals</b>	<b>\$ 10,482,351.78</b>	<b>\$ 10,468,154.02</b>	<b>\$ 14,197.76</b>	<b>100.14%</b>

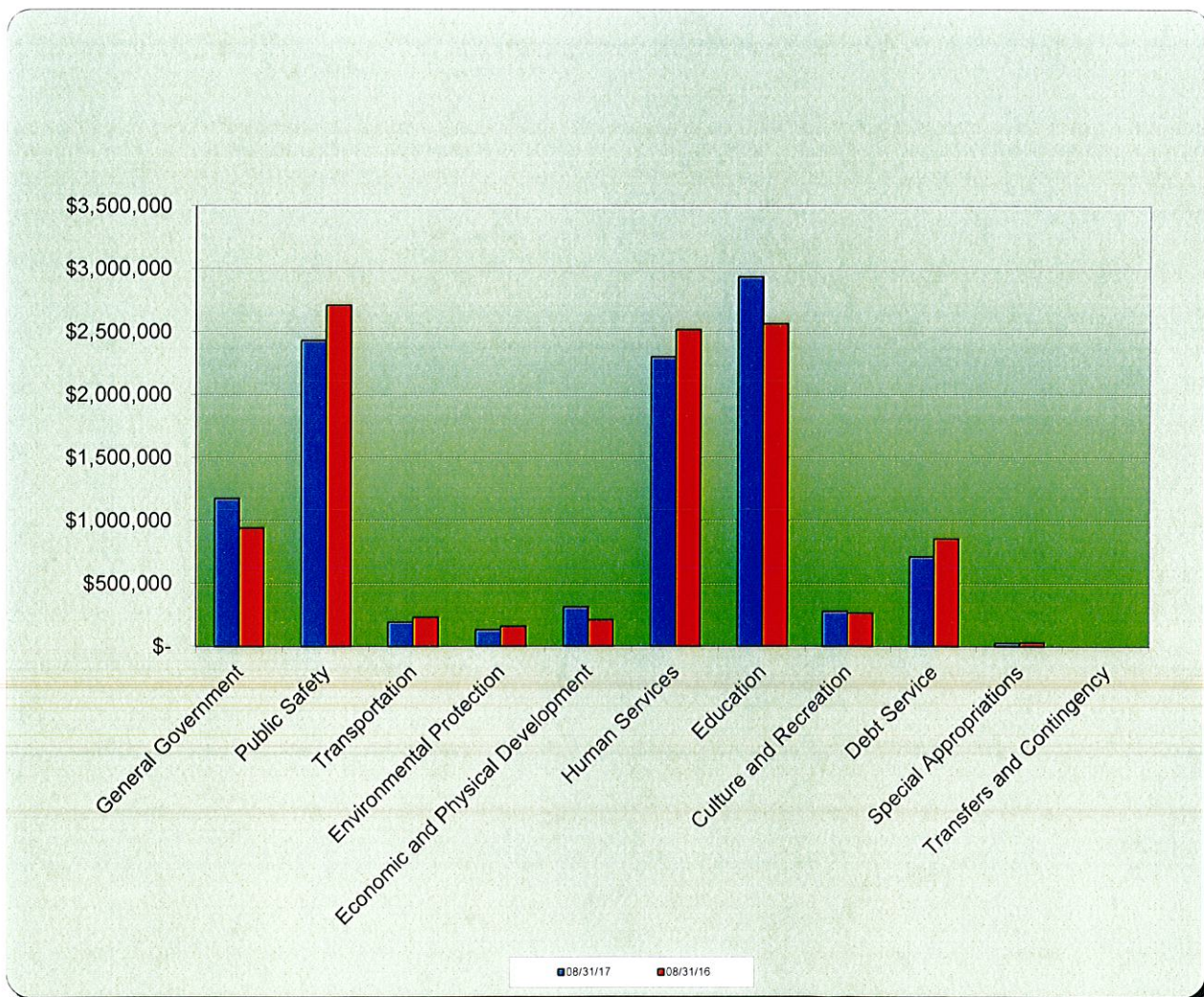



**Stanly County**  
**General Fund Budget by Function Compared to Actual Expenses**  
**For the Two Months Ended August 31, 2017**

EXPENSES:	Amended Budget	Actual	Over/(Under)	Percent Expended
General Government	\$ 5,846,496.00	\$ 1,175,694.85	\$ (4,554,315.83)	22.10%
Public Safety	15,031,973.00	2,430,752.96	(11,958,053.79)	20.45%
Transportation	1,012,465.00	192,075.57	(817,864.43)	19.22%
Environmental Protection	1,284,857.00	128,171.57	(665,210.09)	48.23%
Economic and Physical Development	1,725,767.00	309,664.75	(1,416,102.25)	17.94%
Human Services	17,584,433.00	2,299,889.08	(14,182,872.31)	19.34%
Education	15,817,694.00	2,934,307.41	(12,883,386.59)	18.55%
Culture & Recreation	1,624,780.00	277,085.26	(1,317,875.48)	18.89%
Debt Service	3,352,597.00	709,710.33	(2,642,886.67)	21.17%
Special Appropriations	135,000.00	25,000.00	(110,000.00)	18.52%
Transfers & Contingency	645,572.00	-	(645,572.00)	0.00%
<b>Totals</b>	<b>\$ 64,061,634.00</b>	<b>\$ 10,482,351.78</b>	<b>\$ (51,194,139.44)</b>	<b>20.09%</b>

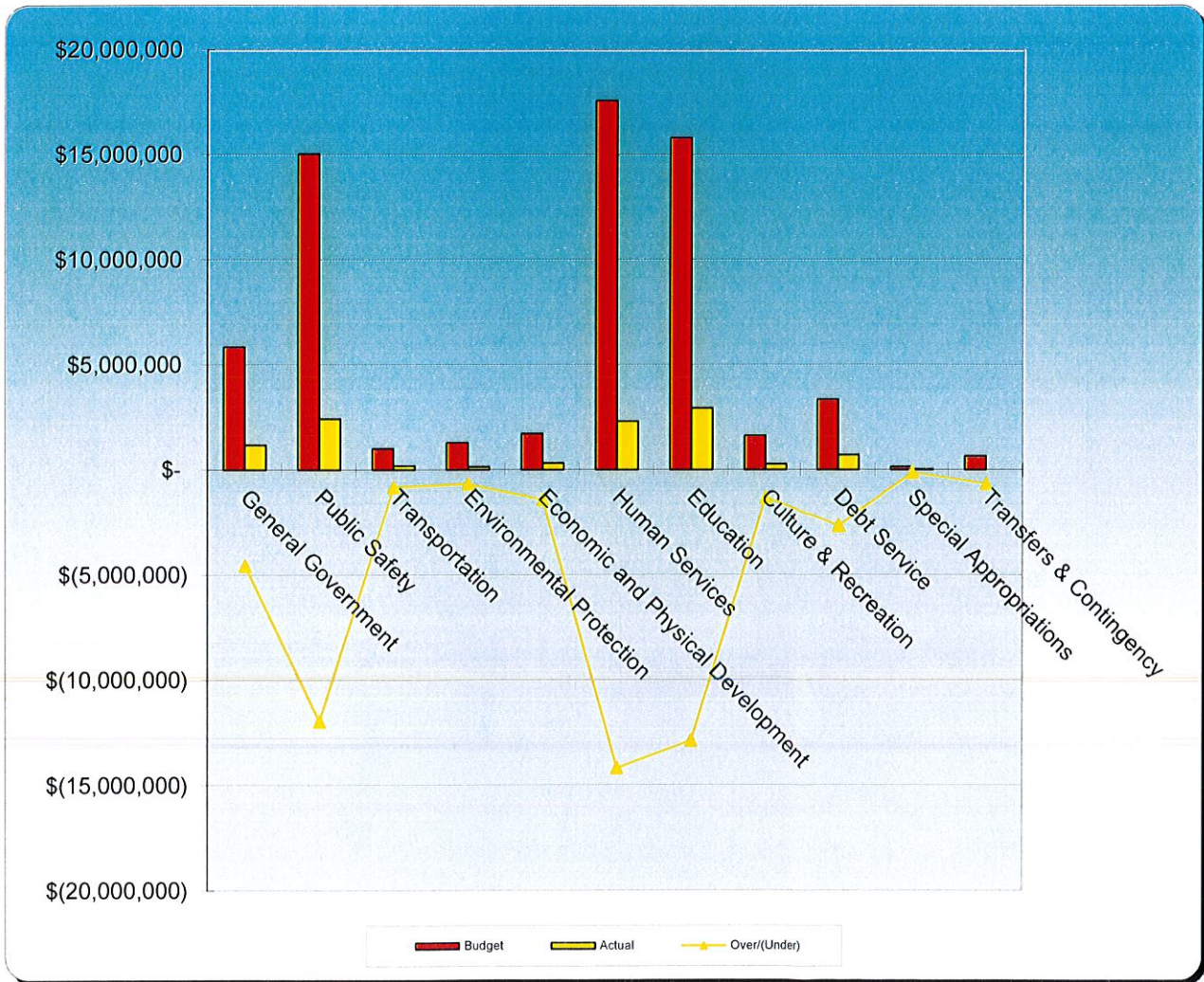



**Stanly County**  
**Comparative Monthly Financial Report**  
**For the Two Months Ended August 31, 2017**

	AMENDED BUDGET	*Y-T-D TRANSACTIONS	UNCOLLECTED REVENUE OR APPROPRIATIONS REMAINING	% COLLECTED OR EXPENDED	LAST YEAR'S Y-T-D TRANSACTIONS
<b>GENERAL FUND 110</b>					
<b>REVENUES:</b>					
Depart 3100- Ad Valorem Taxes	\$ 31,958,948.00	\$ 16,300,856.99	\$ 15,658,091.01	51.01%	\$ 14,606,619.57
Depart 3200- Other Taxes	9,796,500.00	62,414.21	9,734,085.79	0.64%	73,244.68
Depart 3320- State Shared Revenue	695,500.00	13,480.31	682,019.69	1.94%	232,007.50
Depart 3323- Court	125,000.00	18,731.60	106,268.40	14.99%	20,165.18
Depart 3330- Intergovt Chg for Services	170,000.00	94,284.60	75,715.40	55.46%	92,764.34
Depart 3340- Building Permits	605,510.00	102,709.11	502,800.89	16.96%	88,178.24
Depart 3347- Register of Deeds	323,531.00	50,588.23	272,942.77	15.64%	48,391.30
Depart 3414- Tax And Revaluation	1,100.00	25.00	1,075.00	2.27%	55.00
Depart 3417- Election Fees	5,250.00	10.00	5,240.00	0.19%	54.00
Depart 3431- Sheriff	662,665.00	473,681.78	188,983.22	71.48%	70,353.15
Depart 3432- Jail	276,108.00	56,747.94	219,360.06	20.55%	59,043.29
Depart 3433- Emergency Services	44,074.00	8,996.89	35,077.11	20.41%	13,073.01
Depart 3434- FIRE	7,000.00	950.00	6,050.00	N/A	1,375.00
Depart 3437- EMS-Ambulance	2,485,000.00	434,323.31	2,050,676.69	17.48%	374,844.55
Depart 3439- Emergency 911	1,000.00	-	1,000.00	N/A	-
Depart 3450- Transportation	797,197.00	60,129.55	737,067.45	7.54%	114,976.77
Depart 3471- Solid Waste	1,018,320.00	471,002.63	547,317.37	46.25%	458,668.16
Depart 3490- Central Permitting	14,220.00	2,692.50	11,527.50	18.93%	2,303.26
Depart 3491- Planning and Zoning	51,900.00	6,272.31	45,627.69	12.09%	6,234.94
Depart 3492- Rocky River RPO	132,969.00	22,154.36	110,814.64	16.66%	23,125.00
Depart 3494- EDC	110,000.00	-	110,000.00	N/A	-
Depart 3495- Cooperative Extension	21,625.00	2,801.82	18,823.18	12.96%	1,065.32
Depart 3500- Health Department	4,162,248.00	517,343.46	3,644,904.54	12.43%	668,710.28
Depart 3523- Juvenile Justice	101,561.00	8,930.00	92,631.00	8.79%	7,052.00
Depart 3530- Social Services	6,736,552.00	545,346.41	6,191,205.59	8.10%	618,786.15
Depart 3538- Senior Services	241,167.00	34,697.78	206,469.22	14.39%	179,670.29
Depart 3586- Aging Services	677,764.00	28,475.48	649,288.52	4.20%	81,692.01
Depart 3587- Veteran Service	-	-	-	N/A	-
Depart 3611- Stanly County Library	145,550.00	29,364.12	116,185.88	20.17%	25,344.74
Depart 3613- Recreation Plan	-	-	-	N/A	-
Depart 3614- Historical Preservation	-	-	-	N/A	-
Depart 3616- Civic Center	89,750.00	35,070.00	54,680.00	39.08%	10,730.75
Depart 3831- Investments	127,500.00	21,172.14	106,327.86	16.61%	7,768.43
Depart 3834- Rent Income	224,267.00	23,102.75	201,164.25	10.30%	23,102.75
Depart 3835- Sale of Surplus Property	15,000.00	1,887.98	13,112.02	12.59%	1,620.00
Depart 3838- Loan Proceeds	538,468.00	317,674.92	220,793.08	59.00%	-
Depart 3839- Miscellaneous	30,000.00	1,803.07	28,196.93	6.01%	248,684.14
Depart 3980- Transfer From Other Funds	-	-	-	N/A	-
Depart 3991- Fund Balance	1,668,390.00	-	1,668,390.00	N/A	-
<b>TOTAL REVENUES</b>	<b>64,061,634.00</b>	<b>19,747,721.25</b>	<b>44,313,912.75</b>	<b>30.83%</b>	<b>18,159,703.80</b>
<b>GENERAL FUND 110</b>					
<b>EXPENSES:</b>					
Depart 4110- Governing Body	237,845.00	72,854.93	164,990.07	30.63%	71,097.77
Depart 4120- Administration	431,946.00	70,374.83	361,571.17	16.29%	82,659.24
Depart 4130- Finance	479,687.00	63,379.46	416,307.54	13.21%	68,505.69
Depart 4141- Tax Assessor	788,563.00	141,593.79	646,969.21	17.96%	130,870.19
Depart 4143- Tax Revaluation	390,227.00	67,681.08	322,545.92	17.34%	74,730.95
Depart 4155- Attorney	440,724.00	38,134.55	402,589.45	8.65%	32,708.61
Depart 4160- Clerk	12,118.00	-	12,118.00	0.00%	-
Depart 4163- Judge's Office	6,344.00	18.29	6,325.71	0.29%	516.29
Depart 4164- District Attorney	-	-	-	N/A	-
Depart 4170- Elections	403,439.00	59,327.28	341,050.14	15.46%	81,189.49
Depart 4180- Register of Deeds	396,611.00	41,446.01	355,164.99	10.45%	50,870.22
Depart 4210- Info Technology	1,163,806.00	486,962.22	665,770.55	42.79%	167,183.34
Depart 4260- Facilities Management	1,095,186.00	133,922.41	858,913.08	21.57%	178,771.83
<b>Total General Government</b>	<b>5,846,496.00</b>	<b>1,175,694.85</b>	<b>4,554,315.83</b>	<b>22.10%</b>	<b>939,103.62</b>

\* Y-T-D Transactions column does not include encumbrances.



**Stanly County**  
**Comparative Monthly Financial Report**  
**For the Two Months Ended August 31, 2017**

		AMENDED	*Y-T-D	UNCOLLECTED	%	LAST
		BUDGET	TRANSACTIONS	REVENUE OR	COLLECTED	YEAR'S Y-T-D
				APPROPRIATIONS	OR EXPENDED	TRANSACTIONS
				REMAINING		
Depart 4310-	Sheriff	7,452,663.00	1,212,703.71	5,764,608.68	22.65%	1,375,712.82
Depart 4321-	Juvenile Justice	199,061.00	20,992.94	178,068.06	10.55%	14,147.00
Depart 4325	Criminal Justice Partnership	-	-	-	N/A	-
Depart 4326	JCPC	-	-	-	N/A	-
Depart 4330-	Emergency Services	4,697,515.00	845,908.53	3,710,047.38	21.02%	949,723.27
Depart 4350-	Inspections	421,737.00	62,155.77	359,581.23	14.74%	83,632.11
Depart 4360-	Medical Examiner	30,000.00	1,750.00	28,250.00	5.83%	3,600.00
Depart 4380-	Animal Control	381,422.00	58,132.39	318,718.86	16.44%	69,083.00
Depart 4395-	911 Emergency	1,849,575.00	229,109.62	1,598,779.58	13.56%	214,562.47
<b>Total Public Safety</b>		<b>15,031,973.00</b>	<b>2,430,752.96</b>	<b>11,958,053.79</b>	<b>20.45%</b>	<b>2,710,460.67</b>
Depart 4540-	Total Transportation	1,012,465.00	192,075.57	817,864.43	19.22%	229,051.45
Depart 4710-	Solid Waste	1,083,523.00	115,352.49	476,695.17	56.01%	130,042.00
Depart 4750-	Fire Forester	93,000.00	-	93,000.00	0.00%	5,469.27
Depart 4960-	Soil & Water Conservation	108,334.00	12,819.08	95,514.92	11.83%	21,078.24
<b>Total Environmental Protection</b>		<b>1,284,857.00</b>	<b>128,171.57</b>	<b>665,210.09</b>	<b>48.23%</b>	<b>156,589.51</b>
Depart 4902-	Economic Development	592,587.00	157,385.40	435,201.60	26.56%	54,710.19
Depart 4905-	Occupancy Tax	216,500.00	16,214.10	200,285.90	7.49%	19,696.66
Depart 4910-	Planning and Zoning	268,883.00	40,683.46	228,199.54	15.13%	46,871.80
Depart 4911-	Central Permitting	272,892.00	53,660.30	219,231.70	19.66%	53,034.78
Depart 4912-	Rocky River RPO	132,969.00	23,187.34	109,781.66	17.44%	23,457.88
Depart 4950-	Cooperative Extension	241,936.00	18,534.15	223,401.85	7.66%	10,846.70
<b>Total Economic Development</b>		<b>1,725,767.00</b>	<b>309,664.75</b>	<b>1,416,102.25</b>	<b>17.94%</b>	<b>208,618.01</b>
Depart 5100-	Health Department	5,896,993.00	814,958.20	4,362,684.52	26.02%	886,150.04
Depart 5210-	Piedmont Mental Health	205,160.00	33,083.65	172,076.35	16.13%	33,076.60
Depart 5300-	Dept of Social Services	9,917,768.00	1,270,904.43	8,576,323.97	13.53%	1,379,888.99
Depart 5380-	Aging Services	1,069,366.00	119,665.46	645,106.11	39.67%	113,604.66
Depart 5381-	Senior Center	419,960.00	48,345.61	364,827.09	13.13%	88,019.77
Depart 5820-	Veterans	75,186.00	12,931.73	61,854.27	17.73%	14,094.66
<b>Total Human Services</b>		<b>17,584,433.00</b>	<b>2,299,889.08</b>	<b>14,182,872.31</b>	<b>19.34%</b>	<b>2,514,834.72</b>
Depart 5910-	Stanly BOE	14,233,680.00	2,546,983.42	11,686,696.58	17.89%	2,185,370.36
Depart 5920-	Stanly Community College	1,584,014.00	387,323.99	1,196,690.01	24.45%	378,305.65
<b>Total Education</b>		<b>15,817,694.00</b>	<b>2,934,307.41</b>	<b>12,883,386.59</b>	<b>18.55%</b>	<b>2,563,676.01</b>
Depart 6110-	Stanly Library	1,270,891.00	188,641.55	1,064,072.35	16.27%	221,452.02
Depart 6160-	Agri Center	353,889.00	88,443.71	253,803.13	28.28%	40,765.51
<b>Total Culture and Recreation</b>		<b>1,624,780.00</b>	<b>277,085.26</b>	<b>1,317,875.48</b>	<b>18.89%</b>	<b>262,217.53</b>
Depart 9000-	Total Special Appropriations	135,000.00	25,000.00	110,000.00	18.52%	31,250.00
Depart 9100-	Total Debt Service	3,352,597.00	709,710.33	2,642,886.67	21.17%	852,352.50
Depart 9800-	Transfers	356,896.00	-	356,896.00	0.00%	-
Depart 9910-	Contingency	288,676.00	-	288,676.00	0.00%	-
<b>Total Transfers and Contingency</b>		<b>645,572.00</b>	<b>-</b>	<b>645,572.00</b>	<b>0.00%</b>	<b>-</b>
<b>TOTAL EXPENSES</b>		<b>64,061,634.00</b>	<b>10,482,351.78</b>	<b>51,194,139.44</b>	<b>20.09%</b>	<b>10,468,154.02</b>
<b>OVER (UNDER) REVENUES</b>		<b>\$ -</b>	<b>\$ 9,265,369.47</b>	<b>\$ (6,880,226.69)</b>	<b>N/A</b>	<b>\$ 7,691,549.78</b>

**Stanly County**  
**Comparative Monthly Financial Report**  
**For the Two Months Ended August 31, 2017**

		AMENDED BUDGET	*Y-T-D TRANSACTIONS	UNCOLLECTED REVENUE OR APPROPRIATIONS REMAINING	% COLLECTED OR EXPENDED	LAST YEAR'S Y-T-D TRANSACTIONS
<b>EMERGENCY TELEPHONE E-911 260</b>						
<b>REVENUES:</b>						
Depart 3439-	Surcharge	\$ 410,809.00	\$ 34,234.16	\$ 376,574.84	8.33%	\$ 28,895.48
Depart 3831-	Investment Earnings	-	0.69	(0.69)	N/A	4.43
Depart 3991-	Fund Balance	-	-	-	N/A	-
<b>TOTAL REVENUES</b>		<b>410,809.00</b>	<b>34,234.85</b>	<b>376,574.15</b>	<b>8.33%</b>	<b>28,899.91</b>
<b>EXPENSES:</b>						
Depart 4396-	E-911 Operations	410,809.00	110,560.89	300,248.11	26.91%	75,600.26
<b>TOTAL EXPENSES</b>		<b>410,809.00</b>	<b>110,560.89</b>	<b>300,248.11</b>	<b>26.91%</b>	<b>75,600.26</b>
<b>OVER (UNDER) REVENUES</b>		<b>\$ -</b>	<b>\$ (76,326.04)</b>	<b>\$ 76,326.04</b>	<b>N/A</b>	<b>\$ (46,700.35)</b>
<b>FIRE DISTRICTS 295</b>						
<b>REVENUES:</b>						
Depart 3100-	Ad Valorem Taxes	\$ 2,857,098.00	\$ 1,403,866.79	\$ 1,453,231.21	49.14%	\$ 1,205,199.75
<b>TOTAL REVENUES</b>		<b>2,857,098.00</b>	<b>1,403,866.79</b>	<b>1,453,231.21</b>	<b>49.14%</b>	<b>1,205,199.75</b>
<b>EXPENSES:</b>						
Depart 4100-	Comm 1.5 % Admin	52,000.00	8,995.84	43,004.16	17.30%	17,787.93
Depart 4340-	Fire Service	2,805,098.00	44,725.21	2,760,372.79	1.59%	40,796.95
<b>TOTAL EXPENSES</b>		<b>2,857,098.00</b>	<b>53,721.05</b>	<b>2,803,376.95</b>	<b>1.88%</b>	<b>58,584.88</b>
<b>OVER (UNDER) REVENUES</b>		<b>\$ -</b>	<b>\$ 1,350,145.74</b>	<b>\$ (1,350,145.74)</b>	<b>N/A</b>	<b>\$ 1,146,614.87</b>
<b>GREATER BADIN OPERATING 611</b>						
<b>REVENUES:</b>						
Depart 3710-	Operating Revenues	\$ 508,000.00	\$ 43,762.12	\$ 464,237.88	8.61%	\$ 52,814.53
Depart 3991-	Fund Balance Appropriated	-	-	-	N/A	-
<b>TOTAL REVENUES</b>		<b>508,000.00</b>	<b>43,762.12</b>	<b>464,237.88</b>	<b>8.61%</b>	<b>52,814.53</b>
<b>EXPENSES:</b>						
Depart 7110-	Administration	185,000.00	-	185,000.00	0.00%	5,062.77
Depart 7120-	Operations	323,000.00	54,416.24	268,583.76	16.85%	51,700.76
Depart 9800-	Transfer to Other Funds	-	-	-	N/A	-
<b>TOTAL EXPENSES</b>		<b>508,000.00</b>	<b>54,416.24</b>	<b>453,583.76</b>	<b>10.71%</b>	<b>56,763.53</b>
<b>OVER (UNDER) REVENUES</b>		<b>\$ -</b>	<b>\$ (10,654.12)</b>	<b>\$ 10,654.12</b>	<b>N/A</b>	<b>\$ (3,949.00)</b>
<b>PINEY POINT OPERATING 621</b>						
<b>REVENUES:</b>						
Depart 3710-	Operating Revenues	\$ 167,000.00	\$ 16,188.31	\$ 150,811.69	9.69%	\$ 16,083.28
<b>TOTAL REVENUES</b>		<b>167,000.00</b>	<b>16,188.31</b>	<b>150,811.69</b>	<b>9.69%</b>	<b>16,083.28</b>
<b>EXPENSES:</b>						
Depart 7110-	Administration	100,000.00	16,666.66	83,333.34	16.67%	13,333.34
Depart 7120-	Operations	67,000.00	6,057.44	60,942.56	9.04%	240.67
<b>TOTAL EXPENSES</b>		<b>167,000.00</b>	<b>22,724.10</b>	<b>144,275.90</b>	<b>13.61%</b>	<b>13,574.01</b>
<b>OVER (UNDER) REVENUES</b>		<b>\$ -</b>	<b>\$ (6,535.79)</b>	<b>\$ 6,535.79</b>	<b>N/A</b>	<b>\$ 2,509.27</b>



**Stanly County**  
**Comparative Monthly Financial Report**  
**For the Two Months Ended August 31, 2017**

		AMENDED BUDGET	*Y-T-D TRANSACTIONS	UNCOLLECTED REVENUE OR APPROPRIATIONS REMAINING	% COLLECTED OR EXPENDED	LAST YEAR'S Y-T-D TRANSACTIONS
<b>WEST STANLY WWTP 631</b>						
<b>REVENUES:</b>						
Depart 3710-	Grants	\$ -	\$ -	\$ -	N/A	\$ -
Depart 3712-	Operating Revenues	555,229.00	98,786.16	456,442.84	17.79%	89,088.97
Depart 3980-	Transfer From Other Funds	21,000.00	-	21,000.00	N/A	-
<b>TOTAL REVENUES</b>		<b>576,229.00</b>	<b>98,786.16</b>	<b>477,442.84</b>	<b>17.14%</b>	<b>89,088.97</b>
<b>EXPENSES:</b>						
Depart 7110-	Administration	291,250.00	160,288.16	130,961.84	55.03%	156,250.00
Depart 7120-	Operations	284,979.00	37,758.87	233,225.93	18.16%	46,785.83
Depart 9800-	Transfers	-	-	-	N/A	-
<b>TOTAL EXPENSES</b>		<b>576,229.00</b>	<b>198,047.03</b>	<b>364,187.77</b>	<b>36.80%</b>	<b>203,035.83</b>
<b>OVER (UNDER) REVENUES</b>		<b>\$ -</b>	<b>\$ (99,260.87)</b>	<b>\$ 113,255.07</b>	<b>N/A</b>	<b>\$ (113,946.86)</b>
<b>STANLY COUNTY UTILITY 641</b>						
<b>REVENUES:</b>						
Depart 3710-	Grants	\$ -	\$ -	\$ -	N/A	\$ -
Depart 3712-	Operating Revenues	3,593,229.00	358,493.45	3,234,735.55	9.98%	369,411.66
<b>TOTAL REVENUES</b>		<b>3,593,229.00</b>	<b>358,493.45</b>	<b>3,234,735.55</b>	<b>9.98%</b>	<b>369,411.66</b>
<b>EXPENSES:</b>						
Depart 7110-	Administration	426,300.00	68,708.15	356,391.85	16.40%	78,528.63
Depart 7120-	Operations	3,166,929.00	370,124.13	2,707,815.44	14.50%	412,463.17
Depart 9800-	Transfers	-	-	-	N/A	-
<b>TOTAL EXPENSES</b>		<b>3,593,229.00</b>	<b>438,832.28</b>	<b>3,064,207.29</b>	<b>14.72%</b>	<b>490,991.80</b>
<b>OVER (UNDER) REVENUES</b>		<b>\$ -</b>	<b>\$ (80,338.83)</b>	<b>\$ 170,528.26</b>	<b>N/A</b>	<b>\$ (121,580.14)</b>
<b>AIRPORT OPERATING FUND 671</b>						
<b>REVENUES:</b>						
Depart 3453-	Airport Operating	\$ 566,350.00	\$ 77,319.67	\$ 489,030.33	13.65%	\$ 75,094.51
Depart 3980-	Transfer from General Fund	326,896.00	-	326,896.00	N/A	-
<b>TOTAL REVENUES</b>		<b>893,246.00</b>	<b>77,319.67</b>	<b>815,926.33</b>	<b>8.66%</b>	<b>75,094.51</b>
<b>EXPENSES:</b>						
Depart 4530-	Airport Operating	893,246.00	137,631.64	727,194.13	18.59%	145,529.90
<b>TOTAL EXPENSES</b>		<b>893,246.00</b>	<b>137,631.64</b>	<b>727,194.13</b>	<b>18.59%</b>	<b>145,529.90</b>
<b>OVER (UNDER) REVENUES</b>		<b>\$ -</b>	<b>\$ (60,311.97)</b>	<b>\$ 88,732.20</b>	<b>N/A</b>	<b>\$ (70,435.39)</b>
<b>GROUP HEALTH &amp; WORKERS' COMPENSATION 680</b>						
<b>REVENUES:</b>						
Depart 3428-	Group Health Fees	\$ 6,184,371.00	\$ 870,310.17	\$ 5,314,060.83	14.07%	\$ 967,693.76
Depart 3430-	Workers Compensation	437,114.00	425,791.04	11,322.96	97.41%	404,507.24
<b>TOTAL REVENUES</b>		<b>6,621,485.00</b>	<b>1,296,101.21</b>	<b>5,325,383.79</b>	<b>19.57%</b>	<b>1,372,201.00</b>
<b>EXPENSES:</b>						
Depart 4200-	Group Health Costs	6,184,371.00	1,299,698.03	4,884,672.97	21.02%	985,606.29
Depart 4220-	Workers Compensation	437,114.00	432,353.18	4,760.82	98.91%	411,523.73
<b>TOTAL EXPENSES</b>		<b>6,621,485.00</b>	<b>1,732,051.21</b>	<b>4,889,433.79</b>	<b>26.16%</b>	<b>1,397,130.02</b>
<b>OVER (UNDER) REVENUES</b>		<b>\$ -</b>	<b>\$ (435,950.00)</b>	<b>\$ 435,950.00</b>	<b>N/A</b>	<b>\$ (24,929.02)</b>

**Stanly County**  
**Comparative Monthly Financial Report**  
**Project Funds**  
**For the Two Months Ended August 31, 2017**

		PROJECT AUTHORIZATION	PROJECT TO DATE	PROJECT AMOUNT REMAINING
<b>Tarheel Challenge Academy 212</b>				
<b>REVENUES:</b>				
Depart 3590-	Education	\$ 3,092,000.00	\$ 3,092,000.00	\$ -
	TOTAL REVENUES	<u>3,092,000.00</u>	<u>3,092,000.00</u>	<u>-</u>
<b>EXPENSES:</b>				
Depart 5910-	Public Schools	3,092,000.00	3,054,833.76	37,166.24
	TOTAL EXPENSES	<u>3,092,000.00</u>	<u>3,054,833.76</u>	<u>37,166.24</u>
	OVER (UNDER) REVENUES	<u>\$ -</u>	<u>\$ 37,166.24</u>	<u>\$ (37,166.24)</u>
<b>Livestock Arena Construction Project 215</b>				
<b>REVENUES:</b>				
Depart 3980-	Transfer from Other Funds	\$ 75,000.00	\$ 51,674.40	\$ 23,325.60
	TOTAL REVENUES	<u>75,000.00</u>	<u>51,674.40</u>	<u>23,325.60</u>
<b>EXPENSES:</b>				
Depart 6160-	Agri-Civic Center	75,000.00	57,394.40	17,605.60
	TOTAL EXPENSES	<u>75,000.00</u>	<u>57,394.40</u>	<u>17,605.60</u>
	OVER (UNDER) REVENUES	<u>\$ -</u>	<u>\$ (5,720.00)</u>	<u>\$ 5,720.00</u>
<b>Museum Renovation Project Fund 216</b>				
<b>REVENUES:</b>				
Depart 3611-	Library	\$ 70,000.00	\$ 68,500.00	\$ 1,500.00
Depart 3980-	Transfer from Other Funds	130,000.00	105,193.21	24,806.79
	TOTAL REVENUES	<u>200,000.00</u>	<u>173,693.21</u>	<u>26,306.79</u>
<b>EXPENSES:</b>				
Depart 6110-	Library	200,000.00	173,759.41	17,809.89
	TOTAL EXPENSES	<u>200,000.00</u>	<u>173,759.41</u>	<u>17,809.89</u>
	OVER (UNDER) REVENUES	<u>\$ -</u>	<u>\$ (66.20)</u>	<u>\$ 8,496.90</u>
<b>Badin Water Rehab Part A 612</b>				
<b>REVENUES:</b>				
Depart 3710-	Water & Sewer	\$ 2,832,600.00	\$ 2,513,371.14	\$ 319,228.86
Depart 3980-	Transfer from Greater Badin	25,169.00	-	25,169.00
	TOTAL REVENUES	<u>2,857,769.00</u>	<u>2,513,371.14</u>	<u>344,397.86</u>
<b>EXPENSES:</b>				
Depart 7120-	Water Systems	2,857,769.00	2,500,492.75	\$ 357,276.25
	TOTAL EXPENSES	<u>2,857,769.00</u>	<u>2,500,492.75</u>	<u>357,276.25</u>
	OVER (UNDER) REVENUES	<u>\$ -</u>	<u>\$ 12,878.39</u>	<u>\$ (12,878.39)</u>
<b>Badin Water Rehab Part B 613</b>				
<b>REVENUES:</b>				
Depart 3710-	Water & Sewer	\$ 6,179,129.00	\$ 2,538,761.00	\$ 3,640,368.00
	TOTAL REVENUES	<u>6,179,129.00</u>	<u>2,538,761.00</u>	<u>3,640,368.00</u>
<b>EXPENSES:</b>				
Depart 7120-	Water Systems	6,179,129.00	2,913,837.35	\$ 3,256,584.52
	TOTAL EXPENSES	<u>6,179,129.00</u>	<u>2,913,837.35</u>	<u>3,256,584.52</u>
	OVER (UNDER) REVENUES	<u>\$ -</u>	<u>\$ (375,076.35)</u>	<u>\$ 383,783.48</u>



**Stanly County**  
**Comparative Monthly Financial Report**  
**Project Funds**  
**For the Two Months Ended August 31, 2017**

		PROJECT AUTHORIZATION	PROJECT TO DATE	PROJECT AMOUNT REMAINING
<b>West Stanly WWTP Rehab Project 632</b>				
<b>REVENUES:</b>				
Depart 3710-	Water & Sewer	\$ 2,648,894.00	\$ -	\$ 2,648,894.00
	<b>TOTAL REVENUES</b>	<u>2,648,894.00</u>	<u>-</u>	<u>2,648,894.00</u>
<b>EXPENSES:</b>				
Depart 7120-	Water Systems	2,648,894.00	63,753.51	\$ 2,585,140.49
	<b>TOTAL EXPENSES</b>	<u>2,648,894.00</u>	<u>63,753.51</u>	<u>2,585,140.49</u>
	<b>OVER (UNDER) REVENUES</b>	<u>\$ -</u>	<u>\$ (63,753.51)</u>	<u>\$ 63,753.51</u>
<b>Airport Rd Corridor Wastwater 642</b>				
<b>REVENUES:</b>				
Depart 3710-	Water & Sewer	\$ 1,121,043.00	\$ -	\$ 1,121,043.00
	<b>TOTAL REVENUES</b>	<u>1,121,043.00</u>	<u>-</u>	<u>1,121,043.00</u>
<b>EXPENSES:</b>				
Depart 7120-	Water Systems	1,121,043.00	73,222.43	\$ 1,047,820.57
	<b>TOTAL EXPENSES</b>	<u>1,121,043.00</u>	<u>73,222.43</u>	<u>1,047,820.57</u>
	<b>OVER (UNDER) REVENUES</b>	<u>\$ -</u>	<u>\$ (73,222.43)</u>	<u>\$ 73,222.43</u>
<b>Brown Hill Road Waterline 645</b>				
<b>REVENUES:</b>				
Depart 3980-	Transfers From Other Funds	225,000.00	18,107.00	206,893.00
	<b>TOTAL REVENUES</b>	<u>225,000.00</u>	<u>18,107.00</u>	<u>206,893.00</u>
<b>EXPENSES:</b>				
Depart 7120-	Water Systems	225,000.00	24,724.50	\$ 200,275.50
	<b>TOTAL EXPENSES</b>	<u>225,000.00</u>	<u>24,724.50</u>	<u>200,275.50</u>
	<b>OVER (UNDER) REVENUES</b>	<u>\$ -</u>	<u>\$ (6,617.50)</u>	<u>\$ 6,617.50</u>
<b>Utilites Communications System 647</b>				
<b>REVENUES:</b>				
Depart 3980-	Transfers From Other Funds	300,000.00	-	300,000.00
	<b>TOTAL REVENUES</b>	<u>300,000.00</u>	<u>-</u>	<u>300,000.00</u>
<b>EXPENSES:</b>				
Depart 7120-	Water Systems	300,000.00	-	\$ 300,000.00
	<b>TOTAL EXPENSES</b>	<u>300,000.00</u>	<u>-</u>	<u>300,000.00</u>
	<b>OVER (UNDER) REVENUES</b>	<u>\$ -</u>	<u>\$ -</u>	<u>\$ -</u>
<b>UTILTIY HWY 200 WATER PROJECT 656</b>				
<b>REVENUES:</b>				
Depart 3720-	Commercial Loan	\$ 1,500,000.00	\$ -	\$ 1,500,000.00
Depart 3980-	Transfers From Other Funds	159,674.00	159,673.63	0.37
	<b>TOTAL REVENUES</b>	<u>1,659,674.00</u>	<u>159,673.63</u>	<u>1,500,000.37</u>
<b>EXPENSES:</b>				
Depart 7120-	Water Systems	1,659,674.00	159,673.63	\$ 1,500,000.37
	<b>TOTAL EXPENSES</b>	<u>1,659,674.00</u>	<u>159,673.63</u>	<u>1,500,000.37</u>
	<b>OVER (UNDER) REVENUES</b>	<u>\$ -</u>	<u>\$ -</u>	<u>\$ -</u>

**Stanly County**  
**Comparative Monthly Financial Report**  
**Project Funds**  
**For the Two Months Ended August 31, 2017**

		PROJECT AUTHORIZATION	PROJECT TO DATE	PROJECT AMOUNT REMAINING
<b>Airport Taxilane Rehab Project 673</b>				
<b>REVENUES:</b>				
Depart 3453-	Vision 100 Entitlement	\$ 238,223.00	\$ 196,999.76	\$ 41,223.24
Depart 3980-	Transfer From Other Funds	26,471.00	21,888.87	4,582.13
TOTAL REVENUES		264,694.00	218,888.63	45,805.37
<b>EXPENSES:</b>				
Depart 4530-	Airport Operating	264,694.00	218,888.63	\$ 45,805.37
TOTAL EXPENSES		264,694.00	218,888.63	45,805.37
OVER (UNDER) REVENUES		\$ -	\$ -	\$ -
<b>Airport Runway and Taxilane Light 674</b>				
<b>REVENUES:</b>				
Depart 3453-	Vision 100 Entitlement	\$ 76,763.00	\$ -	\$ 76,763.00
Depart 3980-	Transfer From Other Funds	8,529.00	-	8,529.00
TOTAL REVENUES		85,292.00	-	85,292.00
<b>EXPENSES:</b>				
Depart 4530-	Airport Operating	85,292.00	-	\$ 85,292.00
TOTAL EXPENSES		85,292.00	-	85,292.00
OVER (UNDER) REVENUES		\$ -	\$ -	\$ -
<b>Airport Pipe Rehabiliaton 677</b>				
<b>REVENUES:</b>				
Depart 3453-	Vision 100 Entitlement	\$ 81,905.00	\$ 43,092.68	\$ 38,812.32
Depart 3980-	Transfer From Other Funds	9,101.00	-	9,101.00
TOTAL REVENUES		91,006.00	43,092.68	47,913.32
<b>EXPENSES:</b>				
Depart 4530-	Airport Operating	91,006.00	47,880.84	\$ 43,125.16
TOTAL EXPENSES		91,006.00	47,880.84	43,125.16
OVER (UNDER) REVENUES		\$ -	\$ (4,788.16)	\$ 4,788.16



**Stanly County**  
**Comparative Cash Position Report**  
**August 31, 2017 Compared with August 31, 2016**

	Current 8/31/2017	Prior 8/31/2016	Increase (Decrease)
110 General Fund	\$ 31,467,289.90	\$ 30,099,136.57	\$ 1,368,153.33
212 Tarheel Challenge Academy	37,166.24	200,455.94	(163,289.70)
213 Emergency Radio System Project	-	397,390.37	(397,390.37)
214 SCC Cosmetology Project	-	88,583.80	(88,583.80)
215 Livestock	(5,720.00)	-	(5,720.00)
216 Museum Renovation Project Fund	(66.20)	-	(66.20)
240 Community Grant (CDBG) Single Family Rehab 2014	-	(164.00)	164.00
249 Community Grant (CDBG) Single Family Rehab	-	-	-
254 Community Grant (CDBG) Single Family Rehab 2011	-	12,966.23	(12,966.23)
255 Community Grant (CDBG) 2011 Urgent Repair	-	8,694.23	(8,694.23)
256 Community Grant (CDBG) 2011 Infrastructure	-	-	-
257 Community Grant (CDBG) 2012 CDBG Scattered Site	-	(26.00)	26.00
260 Emergency Telephone E-911	(33,868.95)	23,587.96	(57,456.91)
295 Fire Districts	1,350,145.74	1,149,272.09	200,873.65
611 Greater Badin Operating	184,957.20	281,528.29	(96,571.09)
612 Badin Water Rehab Part A	12,877.39	(337,346.55)	350,223.94
613 Badin Water Rehab Part B	(253,535.35)	(123,011.83)	(130,523.52)
621 Piney Point Operating	307,671.26	279,533.67	28,137.59
631 West Stanly WWTP	(56,968.15)	(81,596.96)	24,628.81
632 West Stanly WWTP Rehab	(63,753.51)	(28,117.19)	(35,636.32)
641 Utility Operating	1,621,574.30	1,216,343.82	405,230.48
642 Utility- Airport Rd Corridor Wastewater	(83,143.03)	(33,279.81)	(49,863.22)
644 Utility- Alonzo Rod Meter Project	-	(488.00)	488.00
645 Utility- Brown Hill Road Waterline	(6,617.50)	-	-
659 Utility- Cottonville Rd Waterline Relocat	-	(62,882.00)	-
671 Airport Operating	(91,634.52)	(39,474.94)	(52,159.58)
673 Airport Taxilane Rehab Project	-	(10,330.35)	10,330.35
677 Airport Pipe Rehabilitation	(4,788.16)	-	-
680 Group Health Fund	2,578,112.50	3,461,684.88	(883,572.38)
730 Deed of Trust Fund	4,278.00	3,992.80	285.20
740 Sheriff Court Executions	425.10	25,359.68	(24,934.58)
760 City and Towns Property Tax	5,585,113.14	4,899,193.77	685,919.37
	<u>\$ 42,549,515.40</u>	<u>\$ 41,431,006.47</u>	<u>1,118,508.93</u>

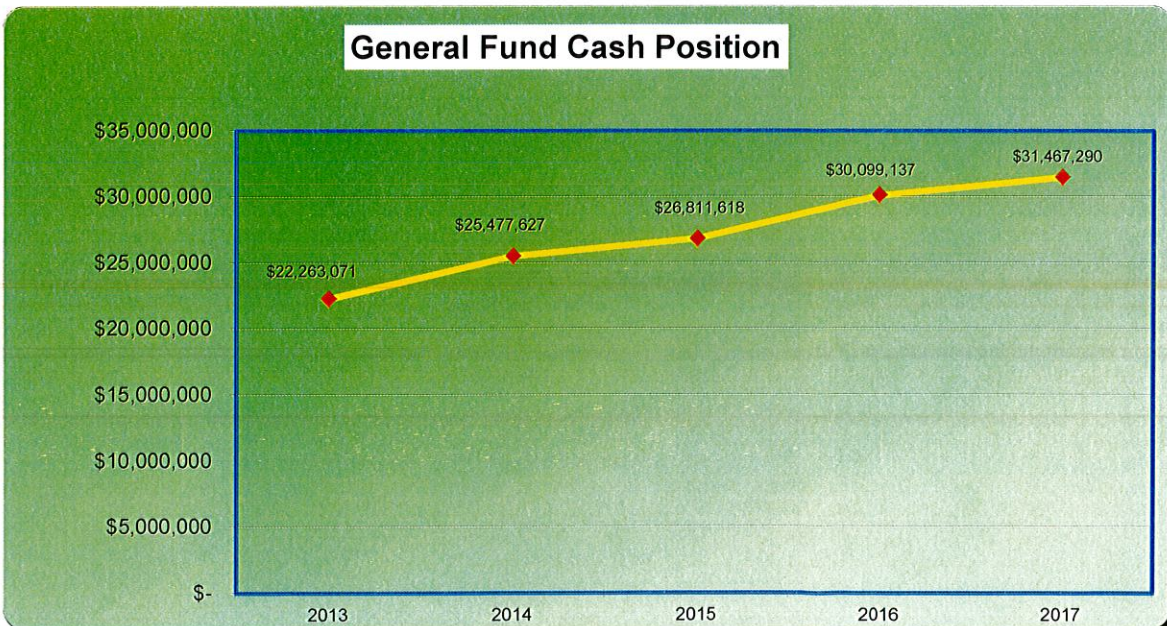



**Stanly County  
Investment Report  
For the Two Months Ended August 31, 2017**

BANK:	Balance per Bank at 8/31/17	% of investment	Purchase Date	Maturity Date	% Yield	Time of Certificate of Deposit
Uwharrie Bank Central Depository	\$ 17,758,196.94	41.43%			1.12%	
Uwharrie Bank Workers Compensation	4,540.32	0.01%			N/A	
Uwharrie Bank Protective Payee	19,958.13	0.05%			N/A	
Uwharrie Bank Money Market	233,842.56	0.55%			0.84%	
NCCMT	1,467,126.06	3.42%			0.89%	
NCCMT Term Portfolio	10,317,465.27	24.07%			1.11%	
Bank of North Carolina Money Market	1,048,690.94	2.45%			0.60%	
Uwharrie Bank Certificate of Deposit	4,000,000.00	9.33%	4/7/2017	10/4/2017	0.75%	180 Days
Bank of North Carolina Certificate of Deposit	4,863,054.44	11.35%	3/15/2017	9/15/2017	0.68%	182 Days
Bank of North Carolina Certificate of Deposit # 2	3,147,679.24	7.34%	4/10/2017	10/10/2017	0.68%	182 Days
<b>Totals</b>	<b>\$ 42,860,553.90</b>					

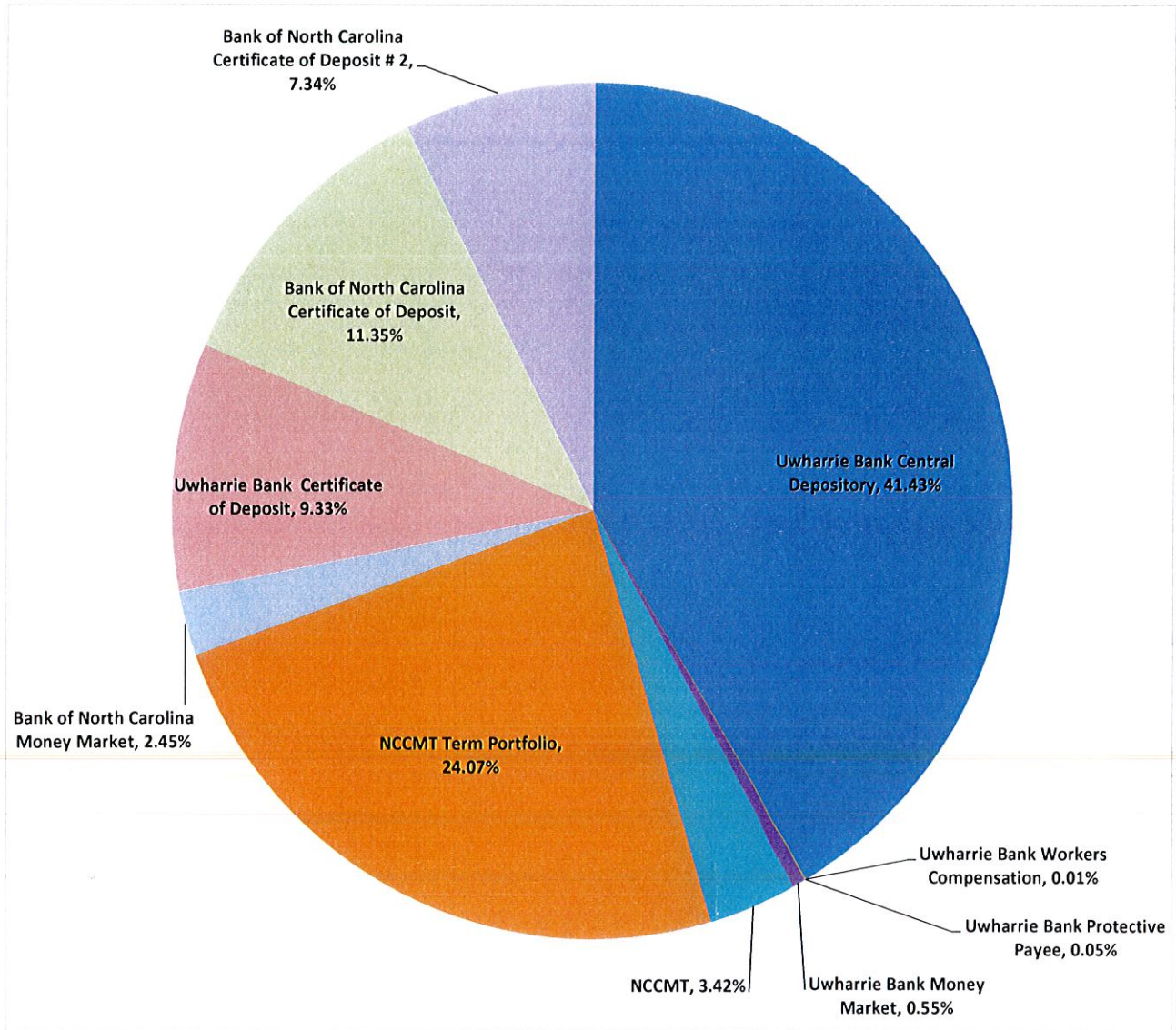



**Stanly County  
Fund Balance Calculation  
As of August 31, 2017**

**Available Fund Balance**

Cash & Investments	\$31,471,549
Liabilities (w/out deferred revenue)	854,217
Deferred Revenue (from cash receipts)	8,499
Encumbrances	2,385,143
Due to Other Governments	30,921

<b>Total Available</b>	<b>\$ 28,192,770</b>
------------------------	----------------------

**General Fund Expenditures**

Total Expenditures	<b>\$ 64,061,634</b>
--------------------	----------------------

**Total Available for Appropriation**

Total Available	\$ 28,192,770
Total Expenditures	64,061,634

<b>Available for Appropriation</b>	<b>44.01%</b>
------------------------------------	---------------



AMENDMENT NO: 2018-05

**STANLY COUNTY-BUDGET AMENDMENT**

BE IT ORDAINED by the Stanly County Board of Commissioners that the following amendment be made to the annual budget ordinance for the fiscal year ending June 30, 2018:

To amend the General Fund 110, the expenditures are to be changed as follows:

FUND/DEPART NUMBER	ACCOUNT NUMBER	ACCOUNT DESCRIPTION	CURRENT BUDGETED AMOUNT	INCREASE (DECREASE)	AS AMENDED
110.4310.4310	261.000	Departmental Supplies	\$ 24,000	\$ 5,400	\$ 29,400
TOTALS			\$ 24,000	\$ 5,400	\$ 29,400

This budget amendment is justified as follows:

To amend the budget for the Sheriff's Office to recognize a donation made by Charlotte Pipe and Foundry Co. to purchase ballistic helmets.

This will result in a net increase \$ 5,400 in expenditures and other financial use to the County's annual budget. To provide the additional revenue for the above, the following revenues will be increased. These revenues have already been received or are verified they will be received in this fiscal year.

FUND/DEPART NUMBER	ACCOUNT NUMBER	ACCOUNT DESCRIPTION	CURRENT BUDGETED AMOUNT	INCREASE (DECREASE)	AS AMENDED
110.3431	840.10	Donations	\$ -	\$ 5,400	\$ 5,400
TOTALS			\$ -	\$ 5,400	\$ 5,400

SECTION 2. Copies of this amendment shall be furnished to the Clerk of the Board of Commissioners, Budget Officer, and to the Finance Director.

Adopted this \_\_\_\_\_ day of \_\_\_\_\_, 20\_\_\_\_

Verified by the Clerk of the Board \_\_\_\_\_

*George J. B...*

Reviewed by Department Head

9/20/17  
Date

*John R. ...*

Reviewed by Finance Director

9-20-17  
Date

Reviewed by County Manager

Date

Posted by
Journal No.
Date





AMENDMENT NO: 2018-06

**STANLY COUNTY-BUDGET AMENDMENT**

BE IT ORDAINED by the Stanly County Board of Commissioners that the following amendment be made to the annual budget ordinance for the fiscal year ending June 30, 2018:

To amend the General Fund 110, the expenditures are to be changed as follows:

FUND/DEPART NUMBER	ACCOUNT NUMBER	ACCOUNT DESCRIPTION	CURRENT BUDGETED AMOUNT	INCREASE (DECREASE)	AS AMENDED
110.4310.4310	121.000	Salaries & Wages-Regular	\$ 2,140,067	\$ 7,500	\$ 2,147,567
TOTALS			<u>\$ 2,140,067</u>	<u>\$ 7,500</u>	<u>\$ 2,147,567</u>

This budget amendment is justified as follows:

To amend the budget for the Sheriff's Office for SWAT and K-9 personnel incentive pay that was approved by the Board.

This will result in a net increase \$ 7,500 in expenditures and other financial use to the County's annual budget. To provide the additional revenue for the above, the following revenues will be increased. These revenues have already been received or are verified they will be received in this fiscal year.

FUND/DEPART NUMBER	ACCOUNT NUMBER	ACCOUNT DESCRIPTION	CURRENT BUDGETED AMOUNT	INCREASE (DECREASE)	AS AMENDED
110.3991	990.000	Fund Balance Appropriated	\$ 1,682,390	\$ 7,500	\$ 1,689,890
TOTALS			<u>\$ 1,682,390</u>	<u>\$ 7,500</u>	<u>\$ 1,689,890</u>

SECTION 2. Copies of this amendment shall be furnished to the Clerk of the Board of Commissioners, Budget Officer, and to the Finance Director.

Adopted this \_\_\_\_\_ day of \_\_\_\_\_, 20\_\_\_\_

Verified by the Clerk of the Board \_\_\_\_\_

*[Signature]*  
Reviewed by Department Head

*9/20/17*  
Date

*[Signature]*  
Reviewed by Finance Director

*9-20-17*  
Date

Reviewed by County Manager \_\_\_\_\_

Date

Posted by
Journal No.
Date